

User manual

PWS1-1725KTL-H-NA/EX-O Power

Conversion System

Sinexcel



Sinexcel

PWS1-1725KTL-H-NA/EX-O Bi-directional Power Conversion System

User manual

Version: V4.0

Filing Date: 2024-03

Version	Date	Description	Author
1.0	2023.04.10	Initial manual release	R&D
2.0	2023.07.24	Modifications related to PCS upgrade	Chloe
3.0	2024.01.12	Rechecked the whole document, including parameters, technical details, descriptions, etc.	Chloe, R&D team
4.0	2024.03.15	Rechecked the whole document, Removed the topology diagram for 2\4 branches Added 8-branch model contents Removed U2 board introduction and added wiring and terminal labeling for U2 control box.	Shane, Chloe, R&D team

Shenzhen Sinexcel Electric Co., Ltd.

All rights reserved. In case of any content change, it shall be without prior notice.

Shenzhen Sinexcel Electric Co., Ltd.

Website: <http://sinexcel.us/> or www.sinexcel.com

Add: Building 6, Area 2, Baiwangxin High-tech Industrial Park, No. 1002, Songbai Road, Nanshan District, Shenzhen

Postcode: 518055

Hotline: +86 0755-8651-1588

Contents

1 OVERVIEW	1
1.1 APPLICABLE MODELS.....	1
1.2 TARGET GROUP.....	1
1.3 TERMINOLOGY.....	2
2. SAFETY INSTRUCTIONS	3
2.1 SAFETY INSTRUCTIONS.....	3
2.2 IMPORTANT SAFETY INSTRUCTIONS	3
2.3 ADDITIONAL INFORMATION	4
3 PRODUCTS	5
3.1 SYSTEM INTRODUCTION.....	5
3.2 APPEARANCE OF BI-DIRECTIONAL ENERGY STORAGE CONVERTER	5
3.3 DIMENSION AND WEIGHT	7
3.4 SYSTEM SCHEMATIC	7
3.5 SYSTEM SCHEMATIC	8
3.6 PCS COMPOSITION.....	9
3.7 OPERATING COMPOSITIONS	11
3.7.1 SWITCHES INTRODUCTION.....	11
3.8 LABELS	14
3.9 HEAT DISSIPATION DESIGN	14
4 PARAMETERS	16
5 STORING、 LIFTING AND TRANSPORTING	17
5.1 TRANSPORT AND STORAGE.....	17
5.2 TRANSPORT	19
5.3 OUT OF THE BOX INSPECTION.....	21
5.3.1 UNPACKING.....	21
5.3.2 INSPECTION	21
6 EQUIPMENT INSTALLATION	22
6. 1 INSTALLATION REQUIREMENTS.....	22
6.1.1 BASIC REQUIREMENTS	22
6.1.2 OUTDOOR REQUIREMENTS	22
6.1.3 FOUNDATION SUPPORT REQUIREMENTS	23
6.1.4 SPACE REQUIREMENTS	24
6.1.5 VENTILATION REQUIREMENTS	25
6. 2 SITE INSTALLATION.....	25
6.2.1 WIRE CHANNEL DESIGN.....	25
6.2.2 FIXING THE PCS.....	26
6.3 ELECTRICAL CONNECTION	27

6.3.1 GENERAL SAFETY RULES.....	27
6.3.2 INSTALLATION TOOLS.....	28
6.3.3 WIRING PARTS.....	28
6.3.4 PREPARATION BEFORE WIRING	29
6.3.5 CABLE SPECIFICATION REQUIREMENTS.....	29
6.3.6 WIRING PRECAUTIONS.....	30
6.3.7 WIRING AREA OVERVIEW	31
6.3.8 DC SIDE WIRING	32
6.3.9 AC SIDE WIRING	33
6.3.10 GROUND CONNECTION	34
6.3.11 WIRING OF TERMINAL STRIPS.....	34
6.3.12 COMMUNICATION	37
6.3.13 INSTALLATION CHECKLIST	37
7 PRODUCT OPERATION.....	38
7.1 CHECK BEFORE OPERATION	38
7.1.1 CHECK CABLE CONNECTIONS	38
7.1.2 CHECK THE PCS	39
7.1.3 CHECK THE BATTERY/GRID SIDE VOLTAGE	39
7.2 POWER ON AND SHUT DOWN	40
7.2.1 POWER ON.....	40
7.2.2 SHUT DOWN	41
7.3 OPERATING MODE.....	42
7.3.1 MAIN FUNCTION	42
7.3.2 OPERATING STATUS INTRODUCTION	42
7.3.3 OPERATING STATE SWITCHING	43
7.4 PROTECTION FUNCTION	44
8 NETWORK MONITORING INTRODUCTION.....	45
8.1 WEB BACKEND FUNCTIONS AND MENU INTRODUCTION.....	45
8.2 NETWORK MONITORING INITIAL STATE DESCRIPTION	46
8.3 LAN PORT CONNECTION.....	46
8.4 THE OPERATION INFORMATION MENU INTRODUCTION	47
8.5 EVENT LOGGING MENU INTRODUCTION.....	48
8.6 INTRODUCTION TO CONTROL & DISPATCHING MENU.....	50
8.7 INTRODUCTION TO THE SETTINGS MENU.....	51
8.8 INTRODUCTION TO THE OPERATION STRATEGY MENU	52
8.9 INTRODUCTION TO LOGIN MENU.....	54
8.10 INTRODUCTION TO ABOUT THIS MACHINE MENU.....	54
9 TROUBLESHOOTING	55
9.1 PRELIMINARY TROUBLESHOOTING.....	55
9.2 LED INDICATOR LIGHT DISPLAY AND TROUBLESHOOTING METHODS	56
9.3 COMMON FAULTS AND TROUBLESHOOTING METHODS	56
9.4 OTHER FAULTS	58

10 MAINTENANCE	59
10.1 SECURITIES & CAUTIONS	59
10.2 MAINTENANCE CYCLE	59
10.3 ELECTRONIC COMPONENTS REPLACEMENT	61
11 APPENDIX	62
11.1 QUALITY ASSURANCE	62
11.2 HMI PROTECTION PARAMETER SETTING INTRODUCTION.....	63
12 CONTACT	65
INSTALLATION INFO	67

1 Overview

1.1 Applicable Models

This file applies to the following models:

PWS1-1725KTL-H series models

This section describes the product model definitions in this manual, as shown in Fig. 1-1:

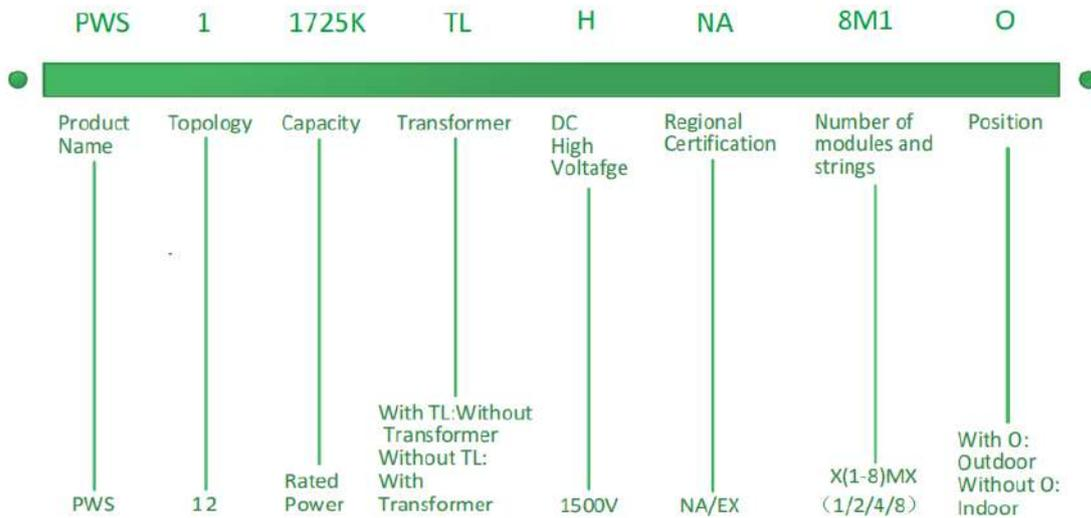

Fig. 1-1 Product Model

For Example:

PWS1-1725KTL-H-NA-8M1-O: Indicates that rated capacity of 1725kW bi-directional single stage energy storage converter without transformer, high voltage 1500V outdoor cabinet. It is 1 DC branch and containing 8 modules with North American version.

Check the nameplate on the PCS to identify the model.

The illustrations in this file are only schematic diagram, please refer to the actual product.

1.2 Target Group

The content described in this document should only be operated by professionals.

Professionals are required to have the following skills:

Understand how the product works and how to operate it.

Understand how batteries work and how to operate them.

Be trained in and understand how to deal with hazards and risks arising from the installation and use of electrical equipment.

Understand the installation and commissioning of electrical equipment.

Understand all applicable standard operating instructions.

Understand and comply with this manual and all safety information.

1.3 Terminology

Terminology	Definition
STS	Static transfer switches
AC	Alternating current
DC	Direct current
BESS	Battery energy storage system
ESS	Energy storage system
EMS	Energy management system
BMS	Battery management system
PCS	Power Conversion System
SLD	Single line diagram
SOH	State of health, expressed in percentage.
SCR	Silicon controlled rectifier
DOD	Depth of discharge, expressed in percentage.
EOD	End of discharge
SOC	Remaining power, expressed in percentage.
UI	User interface
EPO	Emergency power off
SPD	Surge protective devices

2. Safety Instructions

2.1 Safety Instructions

Instruction	
 Danger	Indicates a dangerous situation which, if not avoided, will result in death or serious injury.
 Warning	Indicates a dangerous situation which, if not avoided, will result in death or serious injury.
 Caution	Indicates a dangerous situation which, if not avoided, may result in minor or moderate injury.
 Attention	Indicates that property damage will occur if not avoided.
 Instruction	Please note important information, best practice and advice. Note the information used to resolve issues not related to personal injury, equipment damage and environmental degradation.

2.2 Important Safety Instructions

This user manual for the installation and operation of the PWS1 series 1725kW bi-directional Energy Storage Converters from Sinexcel.

Please read this user manual carefully before installation.

The bi-directional energy storage converters must be commissioned and maintained by an engineer appointed by the manufacturer or an authorized service partner. Failure to do so may endanger personal safety and lead to equipment failure. Damage to the equipment caused as a result is not covered by the warranty.

Bi-directional Energy Storage Converters should not be used in any environment or application associated with life support equipment.

This manual contains important instructions for the PWS1 series models and these instructions should be followed when installing and maintaining the bi-directional energy storage converter.



Any touching of the copper strip, contacts and terminals inside the appliance that are connected to the grid circuit may cause a fatal burn or electric shock!

Do not touch any terminals and wires connected to the grid circuit.

Take note of any instructions and safety documents regarding grid connection.



Warning

Contact with the interior of the appliance may present a risk of electric shock!

Any operation in connection with this appliance must be carried out by qualified personnel.

Please note the safety precautions listed in the safety instructions and installation documentation.

Please take note of the safety precautions listed in the operating and installation manuals and other documentation.



Warning

Massive power leakage

Before connecting the input power, ensure that the earth is securely grounded.

The appliance must be earthed in accordance with local electrical codes.



Warning

When the battery is connected to a bi-directional energy storage converter, DC voltage may be present at the input port. Please take care during operation or check the battery system user manual.



Warning

Do not touch live parts within 5 minutes of power failure!

Dangerous energy is stored in the internal capacitors, so do not touch the terminals, contacts, copper strip, etc. for 15 minutes after disconnecting the appliance from all power sources.



Attention

All internal maintenance and servicing of the equipment should be carried out by trained personnel. Internal components that require the use of tools to open cannot be maintained by the user.

Please read this user manual before operation.

2.3 Additional Information

For further details please click: www.sinexcel.us

3 Products

3.1 System Introduction

PWS1-1725KTL-H series bi-directional energy storage converter (PCS) is a conversion device between the grid and the battery, which can charge and discharge the battery. It can invert the DC power from the battery into AC power that can be connected to the grid and rectify the AC power from the grid into DC power that can be charged into the battery. Bidirectional energy storage converters can be used in on-grid mode or off-grid mode.

3.2 Appearance of bi-directional energy storage converter



Fig. 3-1 Appearance of Bidirectional Energy Storage Converter

Position	Description	Instruction
A	Power indicator	Control circuit power indicator
B	RUN indicator	Always on when the converter is running normally
C	FAULT indicator	Always on when there is a fault, blinking when there is an alarm
D	Emergency stop knob	Press in case of emergency to disconnect AC and DC power immediately
E	AUX knob	Control the inverter aux power*

*The knob is used to control the auxiliary power supply to the rack.

When the AUX knob is rotated to ON, the auxiliary power supply supplies power to the control box and the control box supplies power to the

power module minimum system to ensure communication of the power module. The AC/DC breakers can be controlled to close only when power is supplied to the control box.

When the DC side frame circuit breaker is closed, the control box can be powered by the power module (the control box can be powered by the frame auxiliary power supply individually or by the module individually or both together. It is recommended that both be jointly powered.). The AUX knob should be kept in the ON position during normal operation.

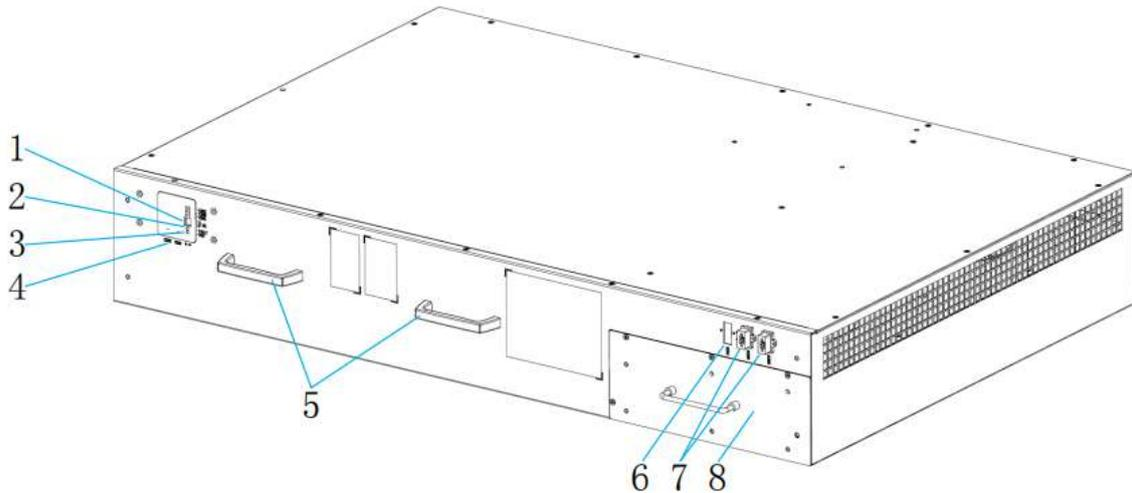

Fig. 3-2 Front view for PCS-AC module

LED designation	Description	Instruction
1	DIP switch	Address
2	Fault indicator light	Red
3	Normal indicator light	Green
4	Communication cable socket	
5	Handle	For pushing and pulling only, not for carrying.
6	24VDC Power supply socket	
7	220VAC Power supply socket	
8	The drawer of Fan	

3.3 Dimension and weight

The dimension of PWS1-1725KTL-H series energy storage converters are marked as shown in Fig. 3-3. The net weight of the product is about 2200kg, and the specific weight is subject to the actual nominal weight.

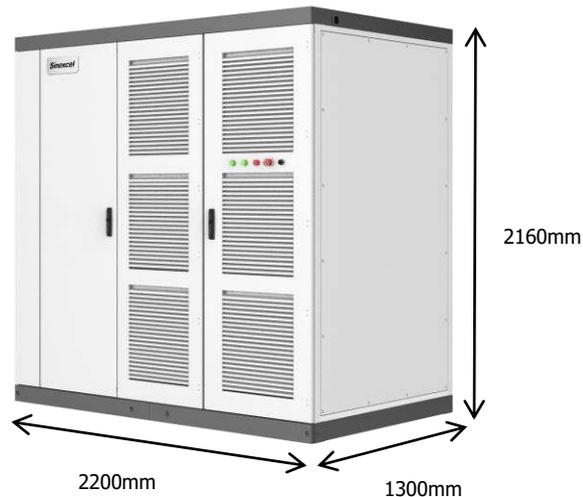

Fig. 3-3 PWS1-1725KTL-H Series Energy Storage Converter External Dimensions

3.4 System schematic

The PWS1-1725KTL-H bi-directional energy storage converter consists of multiple AC modules. The equipment is equipped with SPD protectors, AC and DC switches and auxiliary power distribution units. The schematic diagram of the main circuit inside the energy storage converter is shown in Fig. 3-4. It uses a three-phase three-level topology to realize rectification and inversion. The battery pack interface can be directly connected to the battery, and the AC interface can be connected to the grid or AC load after the isolation transformer or step-up transformer.

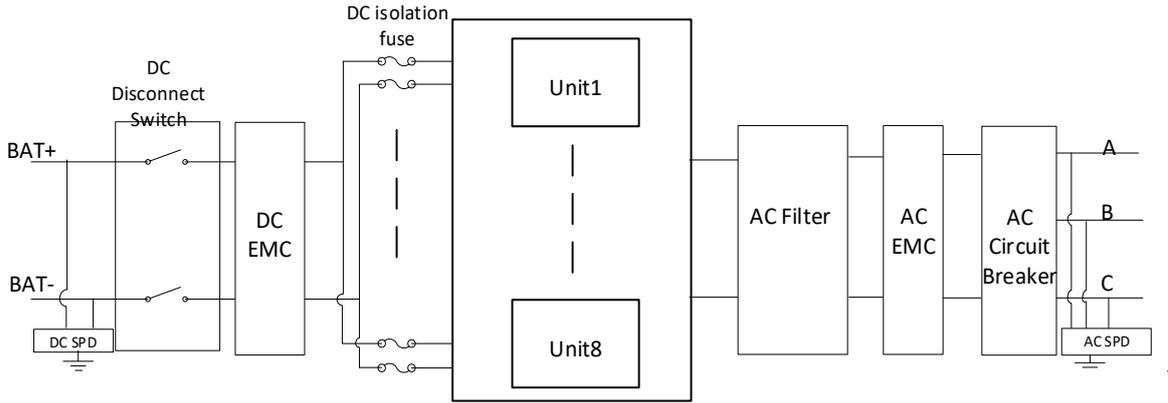

Fig .3-4 Schematic diagram of energy storage converter topology

3.5 System schematic

PWS1-1725KTL-H Bi-directional Storage Inverter (PCS) is composed of 8 PCS-AC modules. The modules identify master-slave systems through the DIP switch dial-up codes on the panel. #1 is a master system, while other modules track the master system. The Bi-directional Storage Inverter (PCS) cabinet is equipped with SPD protector, AC/DC breaker and distribution units. If on/off-grid switching is to be achieved, extra power distribution unit needs to be added. Fig.3-5,3-6 are topological graphs for its composition and structure.

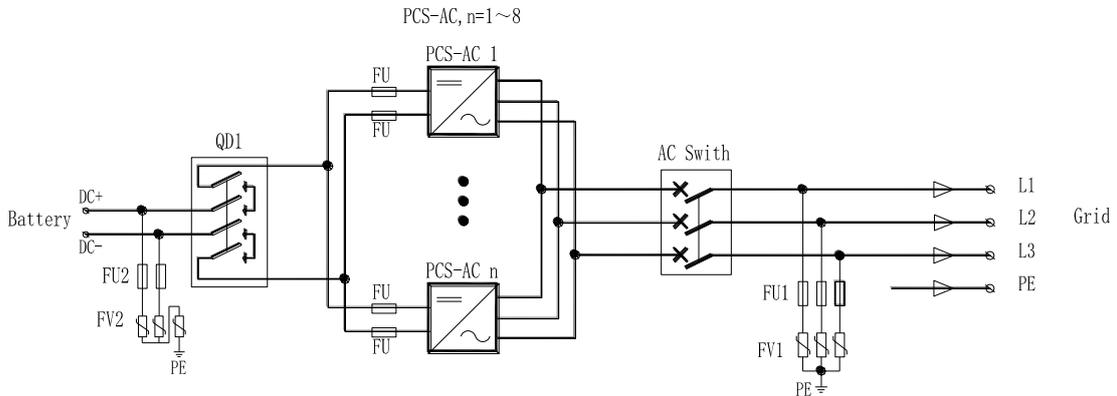

Fig. 3-5 Topological graph for Bi-directional Storage Inverter (PCS) with 1 branch input

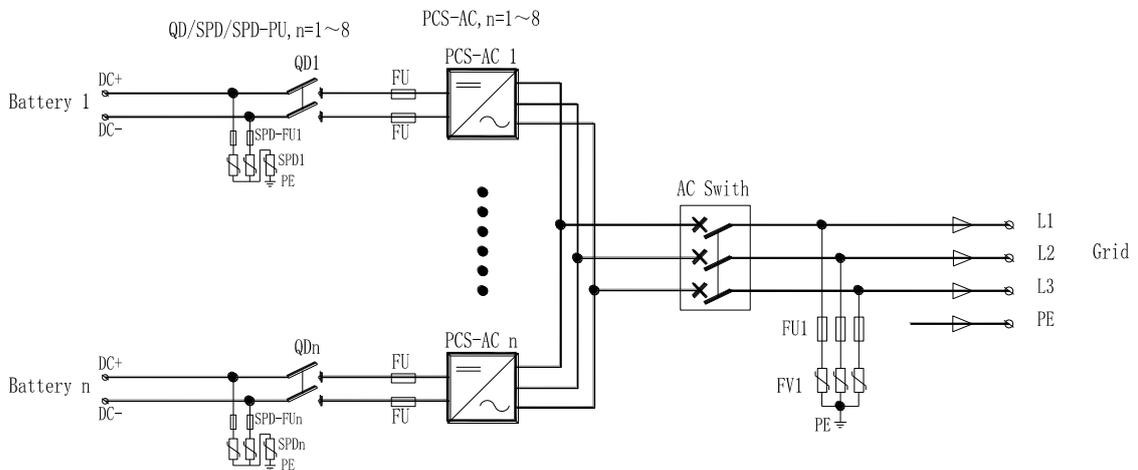

Fig. 3-6 Topological graph for Bi-directional Storage Inverter (PCS) with 8 branches input



NOTICE

Both models have identical mechanical and electrical construction except composed of different sets of DC breakers:

PWS1-1725KTL-H series is composed of 8 sets of PCS-AC modules, the DC branches can be selected of 1 or 8 by different number of DC switches.

Serial No.	Item	Quantity	Remark
1	Cabinet	set	The cabinet is equipped with power distribution
2	PCS-AC module	8 set(s)	
3	Power Management Unit	1 set	
4	DC breaker	1/8 set(s)	

3.6 PCS Composition

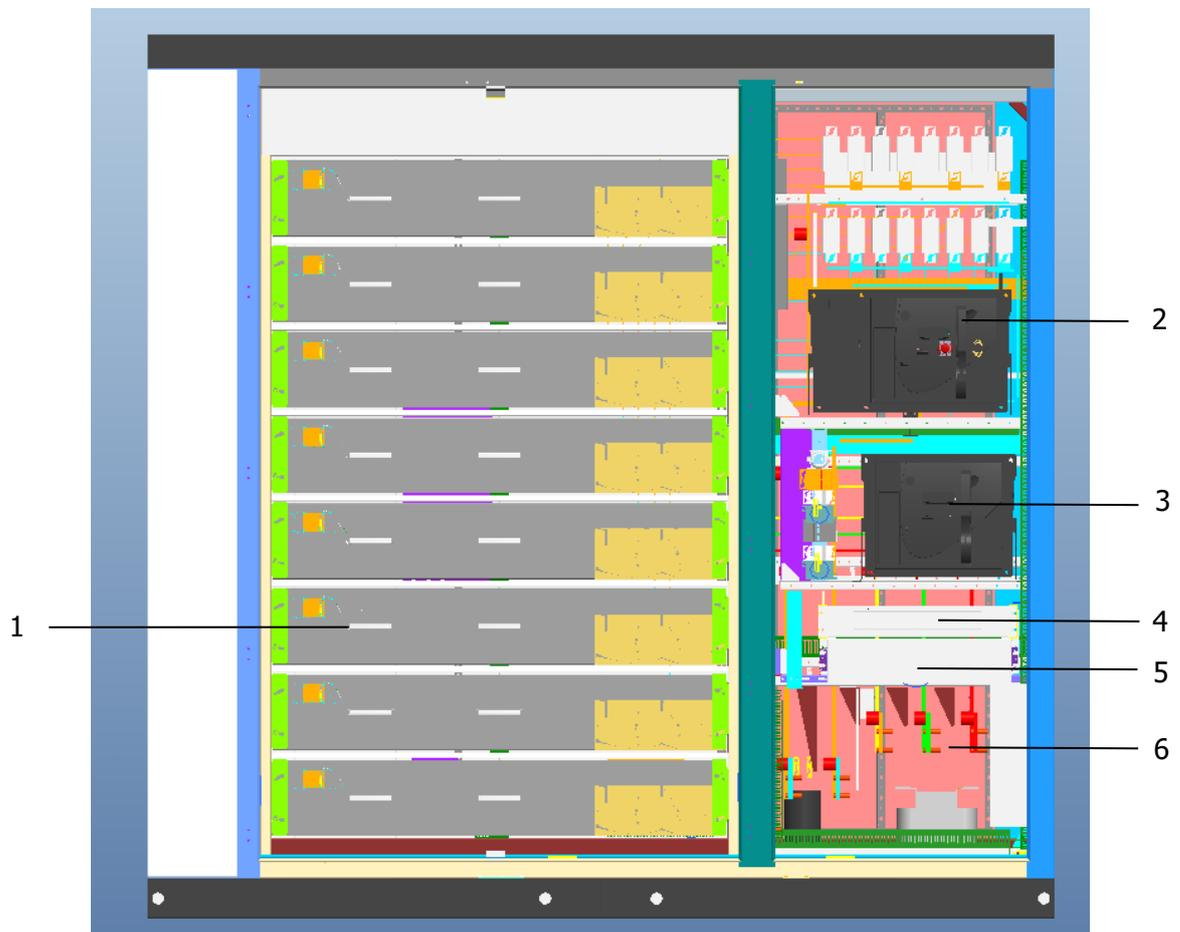

Fig. 3-7 Visible Components of the PCS with 1 branch input

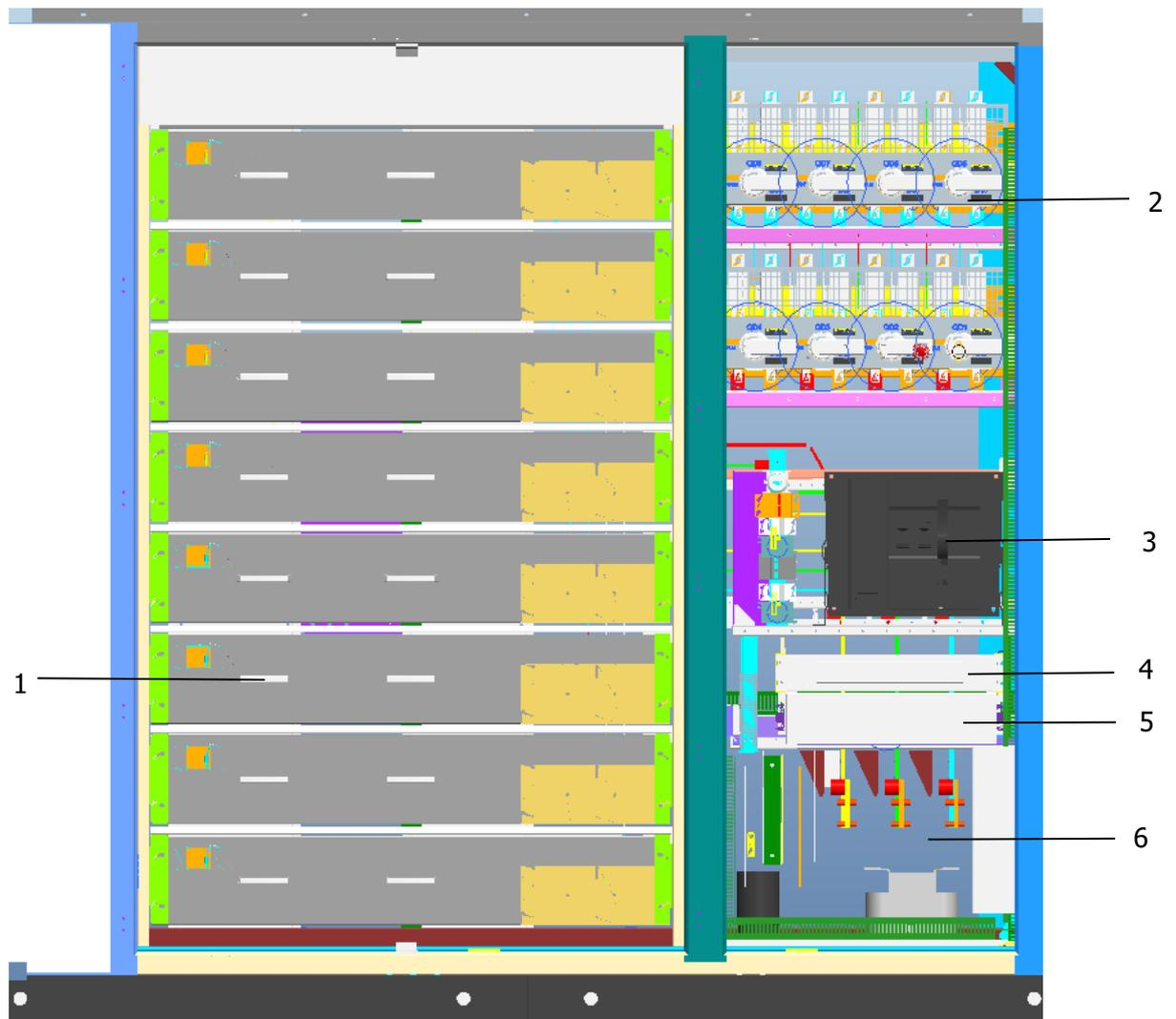

Fig. 3-8 Visible Components of the PCS with 8 branches input

Position	Description	Instruction
1	PCS-AC (1~8 module(s))	215kW 1 set
2	Battery DC Switch	1 or 8 set of DC Switch
3	AC Switch	
4	AUX Power box	
5	Control box	
6	Wiring terminal	

3.7 Operating Compositions

3.7.1 Switches Introduction

3.7.1.1 AC switch

The AC disconnection unit disconnects the PCS from the Grid.



Fig. 3-9 Switch positions of the AC disconnection unit for NA version



Fig. 3-10 Switch positions of the AC disconnection unit for EX version

Position	Description	Instruction	
CLOSED	Switch In On position	The AC connection	unit is closed
OPEN	Switch In OFF position	The AC disconnection	unit is open
CHARGED	Energy storage completion		
DISCHARGED	Unstored energy		

3.7.1.2 DC switch

The DC disconnection unit disconnects the PCS from the Battery module arrays.



Fig. 3-11 Switch positions of the DC disconnection unit for 1 branch

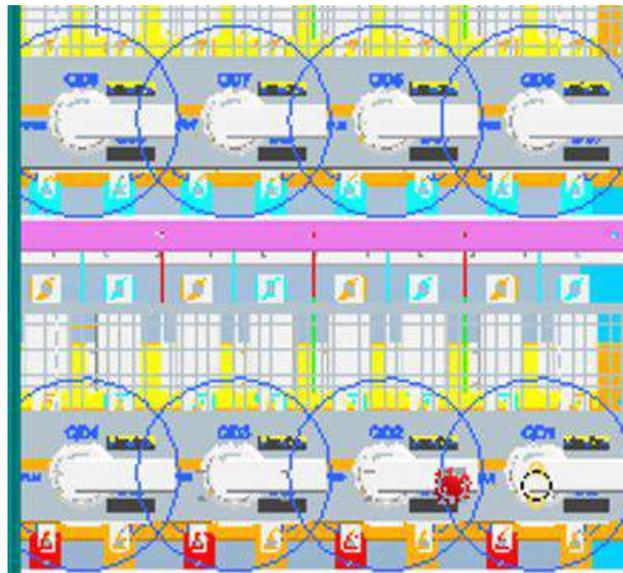

Fig. 3-12 Switching positions of DC disconnection unit for 8 branch

Position	Description	Instruction
ON	Switch In On position	The DC connection unit is closed
OFF	Switch In OFF position	The DC disconnection unit is open
Charged	Energy storage completion	
Discharged	Unstored energy	

3.7.1.3 AUX power supply switch & Fan power switch

AUX power supply can be the redundancy power supply through the AC Switch inside the PCS cabinet.

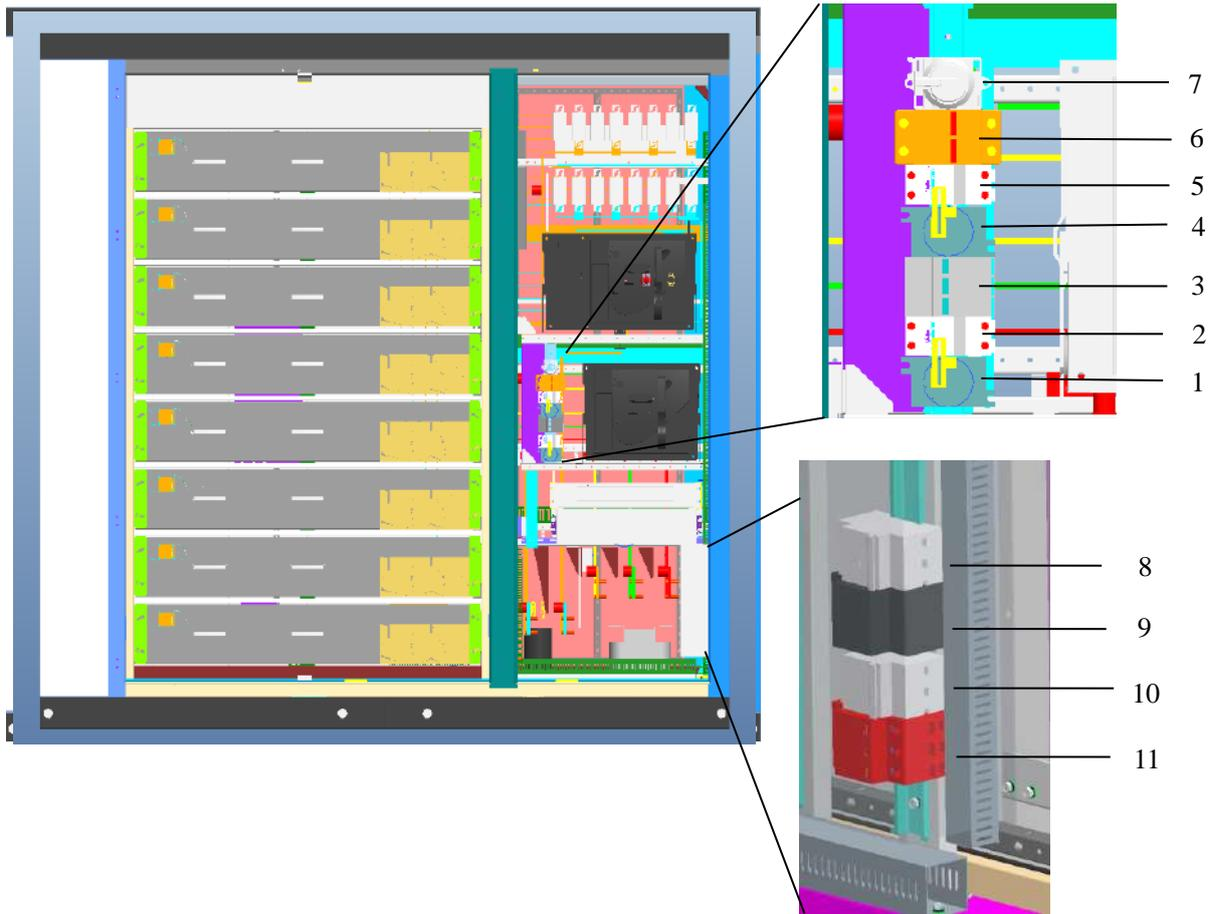

Fig.3-13 Visible Components of the PCS with 1 branch input

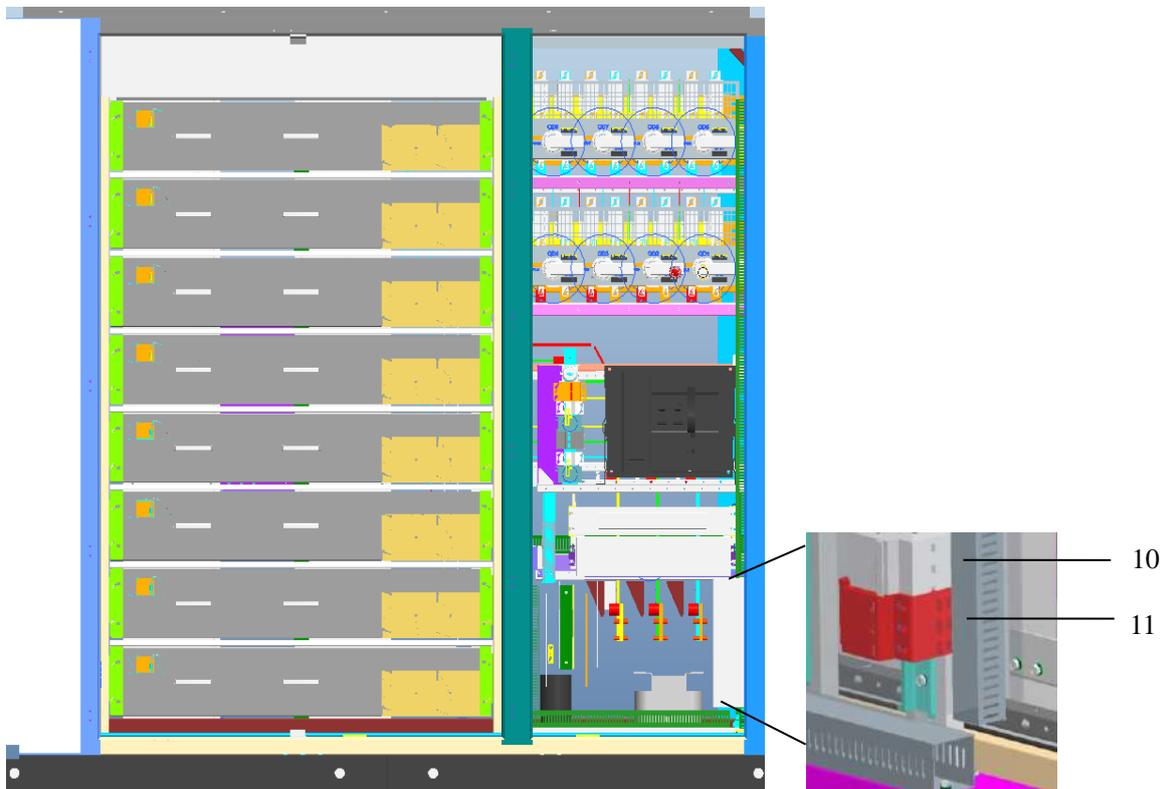

Fig.3-14 Visible Components of the PCS with 8 branches input

Position	Description	Instruction
1	QS1	AUX power supply AC switch
2	QF1	AUX external power supply AC switch
3	FU4	AC fuse
4	QS2	Fan power supply switch
5	QF2	Fan external power supply switch
6	FU3	DC fuse
7	QS3	AUX power supply DC switch
8	FU1	AC fuse
9	FV1	AC SPD
10	FU2	DC fuse
11	FV2	DC SPD

3.8 Labels

No.	Label	Instruction
1		Label-Dot label-L1 phase
2		Label-Dot label-L2 phase
3		Label-Dot label-L3 phase
4		Label-Dot label-Positive electrode
5		Label-Dot label-Negative electrode
6		Label-Dot label-Grounding

3.9 Heat dissipation design

PWS1-1725KTL-H-NA-O series energy storage converter is NEMA3R outdoor unit, the whole adopts the structure design of air inlet on the right side front door panel and air outlet on the left side door. The air outside the cabinet enters through the air inlet hole of the front door panel of the energy storage converter, and the hot air is exhausted through the air duct on the left side door of the PCS. The ventilation design is shown in Fig. 3-13.



Fig. 3-15 PWS1-1725KTL-H series energy storage converter ventilation design

4 Parameters

Technical parameters table

Product Model	PWS1-1725KTL-H-NA-O
DC parameters	
DC voltage range	1070~1500V
Maximum DC current	1612A
Numbers of DC branches	1/8
Utility-interactive Mode	
Nominal AC power	1725kVA
AC voltage	690V(-15%~10%)
AC frequency	50Hz/60Hz(±5Hz)
Nominal AC current	1443A
Output THDi	≤3%
AC PF	-1~+1
Stand-alone Mode	
AC voltage	690V(-15%~10%)
AC frequency	50Hz/60Hz(±5Hz)
Output THDu	≤2% (Linear load)
System parameters	
Peak efficiency	97.5%
AC connection	3-Phase 3-Wire
Isolation	Non-isolation
Cooling	Forced air cooling
Noise	75dB
Operating temperature	-20℃~60℃(De-rating over45℃)
Enclosure	IP54/NEMA3R
Max elevation	3000m/10000feet (> 3000m/10000feet derating)
Humidity	0~95%
Size (WxDxH)	2200*1300*2160 mm
Weight	2200kg(93kg for per power module)
Connection parameters	
Protocol	ModbusTCP/RTU、IEC104、IEC61850
Interface	LAN、RS485、CAN
BMS	Support

5 Storing、lifting and transporting

5.1 Transport and storage

In order to ensure that the energy storage converter is in a better protective state during transportation, please choose to transport with packaging as much as possible, and transport according to the indications of various signs on the packaging. The illustrations of the packaging signs are shown in Table 5-1:

Table 5-1 Description of packaging label

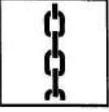
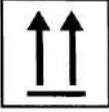
Icon	Description
	Center of gravity mark, indicating the center of gravity of the energy storage converter.
	Lifting mark, indicating the position of the chain or rope when lifting the energy storage converter.
	The upward mark indicates the placement method when carrying and placing the energy storage converter. It is strictly forbidden to put it upside down, horizontally or tilted.
	Handle the logo with care, and avoid violent friction or collision during transportation and placement.
	During transportation and storage, the energy storage converter should be protected from rain or moisture.

NOTICE

Since the center of gravity is not the mechanical center of the energy storage converter, please pay attention to the center of gravity mark on the packaging box during transportation.

NOTICE

Regardless of whether the converter is packaged or not, it is strictly forbidden to tilt an angle greater than 5° during the movement. Due to its large size and weight, an excessively large inclination angle may cause the equipment to fall upside down, causing casualties or equipment damage. Please avoid physical shocks to the equipment during the movement, such as suddenly lowering or lifting.

NOTICE

Please avoid transporting the energy storage converter under rain or bad weather conditions. If it is unavoidable, please take necessary protective measures.

If the on-site installation is not carried out immediately after the completion of the delivery and acceptance work, the energy storage converter with outer packaging should be stored in a ventilated, dry, and clean indoor environment. At the same time, you should also pay attention to the following aspects:

- Restore the package to the state at the time of receipt, and the desiccant in the package must be retained.
- The storage floor is flat and sufficient to carry the weight of the energy storage converter with the outer packaging.
- When storing the equipment, you need to pay attention to ventilation and moisture prevention, and it is strictly forbidden to store water in the storage environment.
- The storage environment temperature is required to be $-40^{\circ}\text{C}\sim+60^{\circ}\text{C}$, and the relative humidity of the storage environment is required to be 0~100%, without condensation.
- Take care to deal with the harsh surrounding environment, such as sudden cold, sudden heat, collision, etc., to avoid damage to the equipment.
- Regular inspections, at least once a week. Check if the packaging is intact to avoid insect bites. If the outer packaging is damaged, it should be replaced immediately.
- If the storage time is more than half a year, the package should be opened for inspection, and the desiccant should be replaced and repackaged.



NOTICE

The energy storage converter is a whole device, and it must not be disassembled during transportation or storage. Equipment failures caused by modifications not authorized by Sinexcel are not covered by the warranty.



NOTICE

When the equipment is transported and stored, it is strictly forbidden to stack, and no other items are allowed to be stacked on the top of the equipment.



NOTICE

When the equipment is transported and stored, it should be ensured that the environment in which it is located is free of corrosive gas, no high-temperature heat source, not excessively dusty, and meets the fire protection requirements. Storage without packaging is strictly prohibited.

5.2 Transport

It is recommended to use a forklift to move the entire box body in a short distance without removing the shipping box. When moving, pay attention to the center of gravity mark and lifting mark position on the box, and ensure that the transportation tool has sufficient carrying capacity. Lifting is strictly prohibited.

Moving the energy storage converter without a packaging box is usually used near the installation location of the equipment. It is recommended to use a forklift for operation. When using a forklift, the bottom baffle of the energy storage converter needs to be removed first.

1) Forklift movement (preferred)

Using a forklift to transport the energy storage converter is a standard way of movement. The center of gravity of the converter should fall between the two forks of the forklift and be pre-inserted to ensure that it will not tilt after being lifted. As shown in Fig. 5-1, the length of forklift forks shall not be less than 1.4m.

In the process of using a forklift to fork, lower and move the energy storage converter, it is necessary to ensure that it is slow and stable, and the energy storage converter must be placed on a firm and level ground.

In the entire process of using a forklift to operate, it is necessary to strictly abide by the forklift safety operation specifications. Due to the large volume of the energy storage converter, it may obstruct the driver's sight, so assistance should be provided for cooperation.



Fig. 5-1 Schematic diagram of forklift

2) Pallet truck movement

The use of a pallet truck to move the energy storage converter is only suitable for conditions where the transportation route is relatively stable. During transportation, the center of gravity of the converter should fall between the two forks of the forklift and be pre-inserted to ensure that it will not tilt after being lifted. As shown in Fig. 5-2, the length of the forklift forks shall not be less than 1.4m, the inner distance between the two fork arms of the pallet truck shall not be less than 0.2m, the outer distance shall not be greater than

0.8m, and the load-bearing capacity of the pallet truck must be $\geq 2400\text{kg}$.

In the process of using a forklift to fork, lower and move the energy storage converter, it is necessary to ensure that it is slow and stable, and the energy storage converter must be placed on a firm and level ground.

In the entire process of using a forklift to operate, the relevant safety operation regulations must be strictly observed. Due to the large size of the energy storage converter, it may obstruct the operator's view, so assistance should be provided for cooperation.

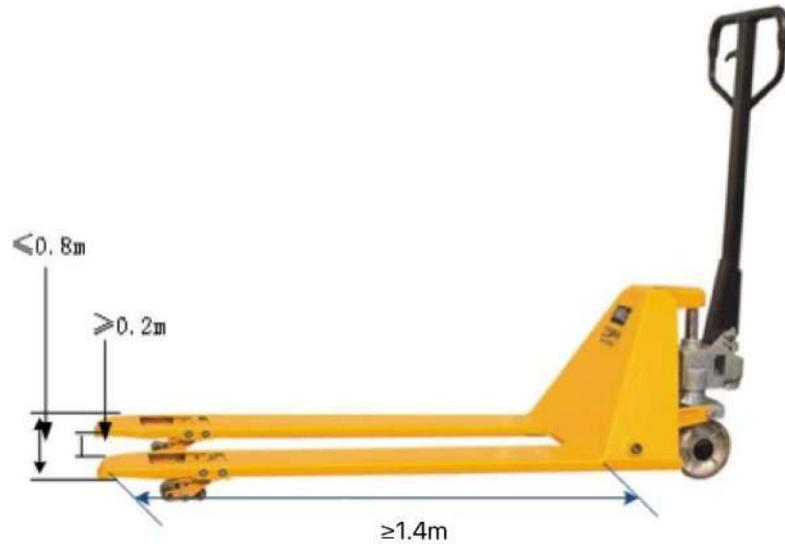

Fig. 5-2 Schematic diagram of pallet truck



NOTICE

Before moving with a forklift or pallet truck, the bottom baffle of the energy storage converter must be removed, otherwise the bottom baffle will be damaged.



NOTICE

No matter which way you choose to move the energy storage inverter, you must ensure:

- Must always pay attention to the position of the center of gravity.
- Must be considered the volume and weight at all times.
- Must be ensured the safety of operators at all times.

Take necessary auxiliary measures to ensure that the equipment is transported to the installation site in good condition.

5.3 Out of the box inspection

5.3.1 Unpacking

When the energy storage converter is transported to the vicinity of the installation site, the transport box needs to be removed. The removal steps are as follows:

- ① Remove the top panel of the box.
- ② Remove the wooden side panel of the packing box.
- ③ Remove the shielding material from the packing box.
- ④ Remove the anchor parts that fix the energy storage converter on the transport wooden bracket.



NOTICE

After removing the anchor parts between the energy storage converter and the transport wooden bracket, it is strictly forbidden to transport the energy storage converter through the wooden bracket.

5.3.2 Inspection

Before leaving the factory, the energy storage converter has been checked by the staff of Sinexcel and packed firmly. Nonetheless, the following items need to be checked after the energy storage converter shipping packaging has been removed:

Check whether the quantity of each item on the packing list is consistent with the actual item;

Check whether the nameplate data of the product is consistent with the order contract, such as product model, rated capacity, voltage level, etc.;

Check whether the factory documents and accessories are complete;

Check whether the appearance of the energy storage converter is consistent with the description in this manual;

Check the energy storage converter for deformation, peeling paint and loose parts.

The packing list of the PWS1-1725KTL-H energy storage converter is shown in Table 5-2.

Table 5-2 Packing list

serial number	name	quantity
1	PWS1-1725KTL-H converter	1 set

(including cabinet door key and related accessories)		
2	Equipment wiring diagram	1 serving
3	Product certification	1 serving
4	Inspection Report	1 serving
5	Warranty Card	1 serving



NOTICE

Installation and debugging can only be carried out on the energy storage converter that has been inspected correctly and is complete without damage. During the inspection process, if any problem is found, please contact the transporter or Sinexcel in time.

6 Equipment installation

6.1 Installation requirements

6.1.1 Basic requirements

The protection level of PWS1-1725KTL-H energy storage inverter is NEMA3R, outdoor placement and installation should ensure a dry and moisture-free working environment. Due to the noise generated during operation, the energy storage inverter should be installed in a location away from residential areas and the installation location should be free from corrosive and combustible gases.

To ensure that the energy storage inverter can operate safely and efficiently, it is important to observe the following when selecting the installation environment.

- The energy storage integrated cabinet must be mounted on a suitable concrete support with a refractory surface, and the converter inlet and outlet must not be obscured.
- The installation ground is dry and flat, no water accumulation, the ground level does not shake, and it can completely carry the weight of the energy storage inverter.
- Installation site ambient temperature range: $-40^{\circ}\text{C} \sim +60^{\circ}\text{C}$; relative humidity range: 0~100%, non-condensing.
- Energy storage inverter grounding resistance $<4\Omega$.
- Cabinet should be installed in a location that ensures easy viewing of the LED indicators.
- If the machine is placed directly outdoors, it is recommended to take the necessary shading measures for the machine to avoid the machine temperature rising due to direct sunlight, causing the machine to run at reduced capacity.

6.1.2 Outdoor requirements

PCS is capable of operating within an ambient temperature of -20°C to 60°C .

When the ambient temperature is higher than 50°C the machine will run at a decreased rate. When the temperature is lower than -20°C, it needs to warm up first before high power operation.

The sunlight irradiation intensity should be $\leq 1200\text{W/m}^2$, and it is recommended that the inverter installed outdoors should take the necessary shading measures.

6. 1. 3 Foundation support requirements

Since the PCS is front air outlet, it is recommended to ensure at least 1m of air duct at the front side, and at least 1.5m of air duct at the left side when installing the PCS.

PCS needs to be installed on a concrete foundation or a structure supported by steel channels with a flame retardant material on the surface. It must be ensured that the foundation is flat and solid, safe and reliable, and has sufficient bearing capacity. It is strictly forbidden to install on a foundation with a depressed or inclined surface.

When building the foundation, the cable trench should be pre-designed according to the overall design of the power station and the location of the cable in and out of the bottom of the PCS.

Holes need to be cut in advance on the foundation, and the size of the holes must be exactly the same as the positioning holes of the base of the PCS, so as to connect the energy storage converter to the foundation firmly.

As shown in Fig. 6-1, The PCS cabinet base has 12 14mm*25mm positioning waist holes. It is recommended to use 8.8-grade M12*50 bolts to fix the PCS cabinet base to the foundation.

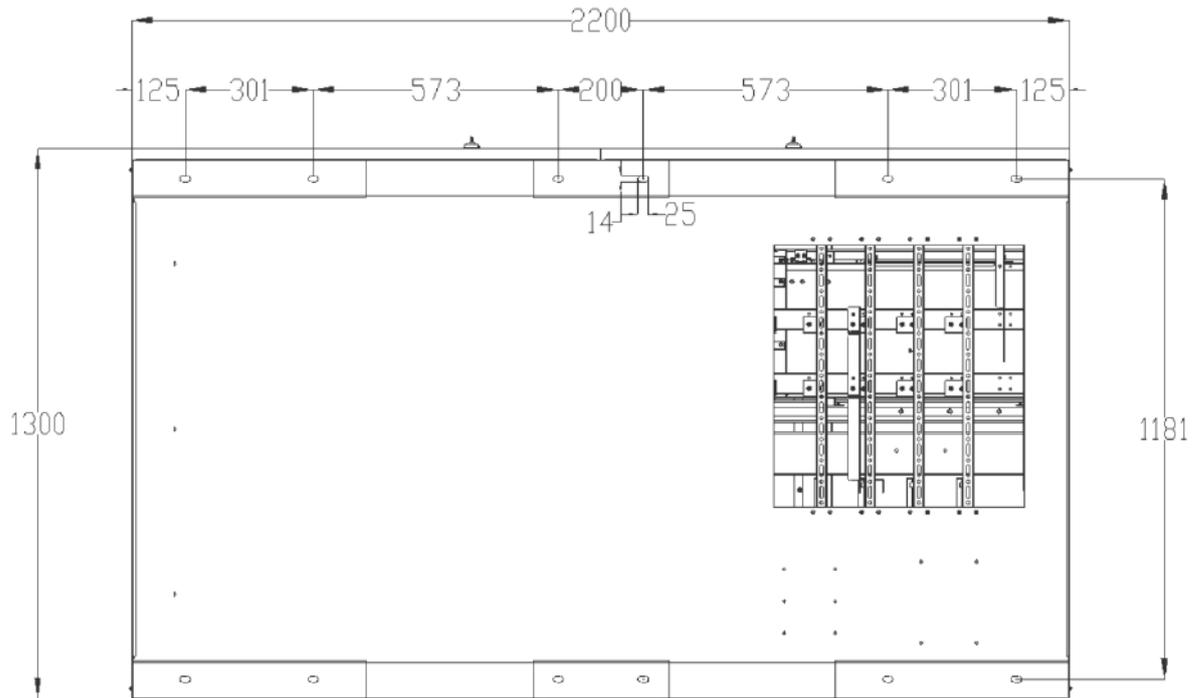

Fig. 6-1 Bottom view of the PCS

6.1.4 Space requirements

As shown in Figure 6-2, the energy storage converter must be installed with sufficient distance from walls and other equipment to allow for the minimum maintenance access, evacuation routes, and ventilation requirements. This subsection requirement is the minimum space requirement for normal operation of the PCS. If site conditions permit, it is recommended that a larger spacing be selected to ensure reliable and efficient operation of the PCS.

- A ≥ 1500mm
- B ≥ 0mm
- C ≥ 1500mm
- D ≥ 0mm



Fig. 6-2 Space requirements for energy storage converter

6.1.5 Ventilation requirements

The converter will generate a lot of heat when running, and the high temperature will directly affect the electrical performance of the equipment and even damage the equipment, so the ventilation and heat dissipation needs of the equipment should be fully considered when planning the installation environment of the converter to ensure the normal and efficient operation of the equipment.

To ensure the reliable and efficient operation of the energy storage cabinet, please regularly clean the grille, filter and filter cotton of the air inlet and outlet of the equipment, and regularly check whether the equipment exhaust fan is functional.

In order to meet the ventilation requirements of the integrated energy storage cabinet, its installation environment needs to meet the following requirements.

- 1) The energy storage cabinet should be avoided to be installed in poor ventilation conditions and low air flow.
- 2) The air inlet should have sufficient fresh air supply.
- 3) Air quality must be ensured. If the air contains too much sand, dust and other suspended matter, the air purity can be improved by installing filters at the air supply grille and other measures.
- 4) The ventilation system of the energy storage cabinet must be independent of the ventilation system of other equipment and do not affect each other.

Cooling ducts should be designed by professionals in advance to avoid placing the cabinet at backflow wind phenomenon. At the same time, each combination must be sealed to prevent air leakage, the choice of sealing materials to withstand the temperature of at least 80°C. After installing the cooling duct, cabinet interior should be checked to prevent screws, gaskets and other debris fall during installation process.

6.2 Site installation

6.2.1 Wire channel design

The inlet and outlet cables are connected to the cabinet at the bottom. For ease of installation and maintenance, it is recommended that the cables connected with the outside are wired from the cable trench. Energy storage cabinet installation foundation should be pre-set under the concrete cable trench, or at the foundation with installed bracket to raise the installation surface, and cables are laid in the overhead. Foot screw or channel steel could be used to fix the cabinet installed with pre-set cable trench. If cabinet is installed in the overhead, it can be installed directly fixed on the bracket.

The cable trench is usually designed and constructed in accordance with the relevant standards, considering the weight of the required cables and the space.

The cross section of the trench is shown in Fig. 6-3. The quantities of cable brackets refers to the user's demands. In order to facilitate the installation and maintenance, the DC circuit and AC circuit should be laid separately.

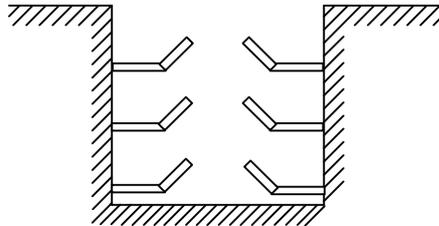

Fig. 6-3 Cross-sectional view of the trench

6.2.2 Fixing the PCS

If the final fixing of the energy storage converter on the channel steel, it is necessary to ensure that the cable trench is laid and the slotted holes meet the installation requirements of the energy storage converter before the final fixing of the equipment. If the energy storage converter is finally fixed on the concrete floor, holes need to be punched in the floor and the energy storage converter needs to be fixed firmly with expansion screws. The fixing method of the energy storage converter is shown in Fig. 6-4.

The fixing of the energy storage converter needs to be done according to the following steps.

- 1) Select the appropriate tool to transport the energy storage converter to the installation position and align the installation hole.
- 2) Use M12*50 bolts to fix the energy storage converter on the channel steel or foundation through the base.
- 3) Install the base baffle of the energy storage converter to complete the fixed installation of the energy storage converter.

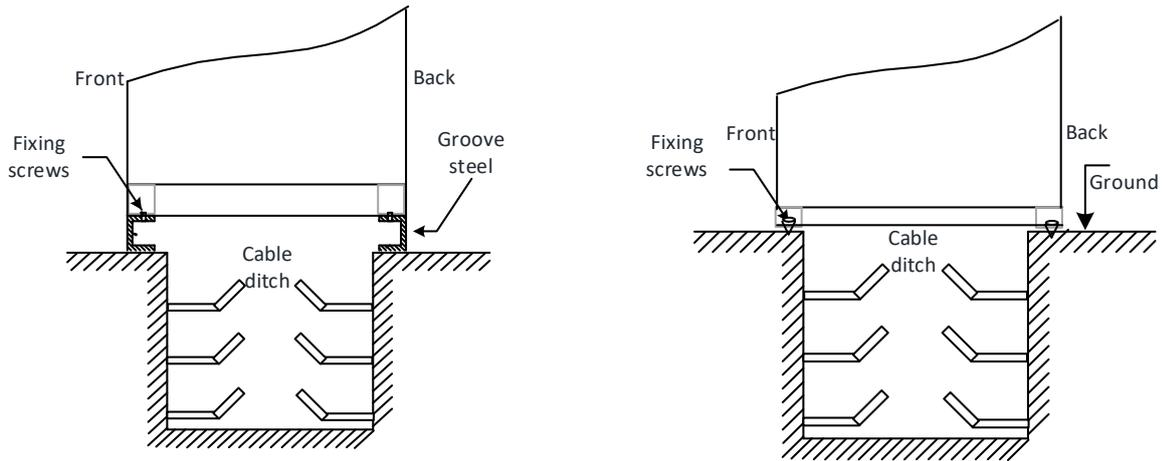

(a) Schematic diagram of the converter fixed to the channel (b) Schematic diagram of the converter fixed to the ground

Fig. 6-4 Energy storage integrated cabinet fixing way

6.3 Electrical connection

6.3.1 General safety rules



Danger

Danger of electric shock!

Please make sure that the installation cables and equipment are not charged before installation.

The capacitor inside the energy storage converter is a hazardous energy storage device, do not place flammable and explosive substances near the energy storage converter.



Warning

All electrical connections must comply with the electrical connection standards of the country where the project is located.

Energy storage converters should only be connected to DC with the permission of the local power company and only after installation by a qualified technician.



Warning

Only a qualified electrician or a qualified person should make the electrical connections to this product. Please strictly follow the wiring signs inside the device.

The following safety rules must be observed throughout the electrical connection of the energy storage converter and during subsequent maintenance and repair operations.

- Disconnect all external connections to the energy storage converter and to the internal power supply of the device.
- Ensure that the energy storage converter is not accidentally re-powered.
- Use a multimeter to make sure that the inside of the energy storage converter is completely de-energized.
- Apply the necessary ground connections.
- Insulate and cover the adjacent potentially energized parts of the operating section with a fabric made of insulating material.

6.3.2 Installation tools

The following tools are required prior to installation.

- Torque wrench
- Screwdriver
- Wire stripper
- Terminal crimping machine
- Hot air gun (or hot air blower)
- Multimeter

6.3.3 Wiring parts

The parts such as fixing screws for the power cable connection of the energy storage converter have been packed in a uniform bag when the equipment is delivered, so please connect the cables in strict accordance with the screw fastening rules.



Attention

When connecting the cables, make sure that the connectors are tightened.

Inadequate connection or oxidation of the contact surface may cause local heat accumulation, which may lead to fire and combustion.



Attention

When wiring the power line, use copper wire of appropriate size and use copper terminals to fix it tightly before connecting it to the wiring copper strip.

6.3.4 Preparation before wiring

- 1) Open the front cover of the energy storage outdoor cabinet

The user needs to open the lower front cover of the energy storage converter before wiring.

- 2) Open the inlet hole

The overall design of the energy storage outdoor cabinet adopts the structure of lower inlet and lower outlet, and the inlet hole is reserved for the user at the bottom of the converter, and the connection lines with the outside are all accessed from the bottom of the machine. In order to prevent foreign objects from entering or leaving the machine during transportation, the delivered equipment has an inlet hole baffle at the bottom, and the inlet hole baffle needs to be removed before wiring.

6.3.5 Cable Specification Requirements

The cable selection requirements are as follows:

- The selected cable must have sufficient current-carrying capacity. The current-carrying capacity of the conductor is related to the environmental conditions, the type of conductor insulation, the laying method, the wire material and the cross-sectional area.
- The wire diameter of all cables must be selected in accordance with the maximum current on either side of the energy storage converter, and a margin must be left.
- The same side of the connection line should choose the same size and type of wire.
- Please use flame retardant cables.

The recommended specifications for the connection cable diameter are shown in Table 6-1.

Table 6-1 Recommended specifications for connection cables

Cable	Wire diameter requirement	Mounting bolt specifications
Battery side DC+	7 branches , 120mm ² each; other types of cables can also be selected, but the total line diameter must not be less than 840mm ² .	M12*40
Battery side DC-	7 branches , 120mm ² each; other types of cables can also be selected, but the total line diameter must not be less than 840mm ² .	M12*40
AC side L1	6 branches per phase , 120mm ² each; other types of cables are also	M12*40

phase	available, but the total line diameter of each phase must not be less than 720mm ²	
AC side L2 phase		M12*40
AC side L3 phase		M12*40
Ground Line	2 branches , 120mm ²	M8*20
Communication line	2*0.75mm ² , It is recommended to use shielded cable	-



Attention

It is strictly forbidden to overload the cable, and the current distributed on the 1mm² cable is strictly forbidden to exceed 3A.

6.3.6 Wiring Precautions



Attention

Before all electrical wiring is performed, all connecting cables must be insulated and inspected for completeness.

Use of poorly insulated, partially exposed or otherwise damaged cables is strictly prohibited.



Attention

Before wiring, make sure that the polarity of either side of the cable is correct.

During wiring, do not pull on the cable to avoid damaging its insulation properties.

All cables need to maintain an adequate bend radius.

Take the necessary auxiliary measures to reduce the stress on the cable.

The length of the screws should be selected appropriately; screws that are too long may affect the insulation performance of the equipment.

Installation should prevent part of the heat-shrinkable sleeve from being sandwiched between the copper nose and the copper row, otherwise it may lead to poor contact and even damage the equipment.

After each step of the wiring operation, it should be carefully checked to ensure that the wiring is correct and firm.



Attention

Incorrect wiring may cause fire and combustion, so please pay attention to the connection order of wiring components.

When connecting, make sure that the connections are tight. Inadequate connection or oxidation of the contact surface may cause local heat accumulation and may lead to fire and combustion.



Attention

After all the electrical connections are completed, the wiring should be fully checked to confirm that it is correct, and then use fireproof mud to seal the gap at the entrance of the wire to prevent small animals from entering.

6.3.7 Wiring Area Overview

The input and output terminals of the energy storage converter are all located at the bottom of the cabinet, the terminals are arranged as shown in the Fig. 6-5, 6-6, please connect them correctly according to the logo.

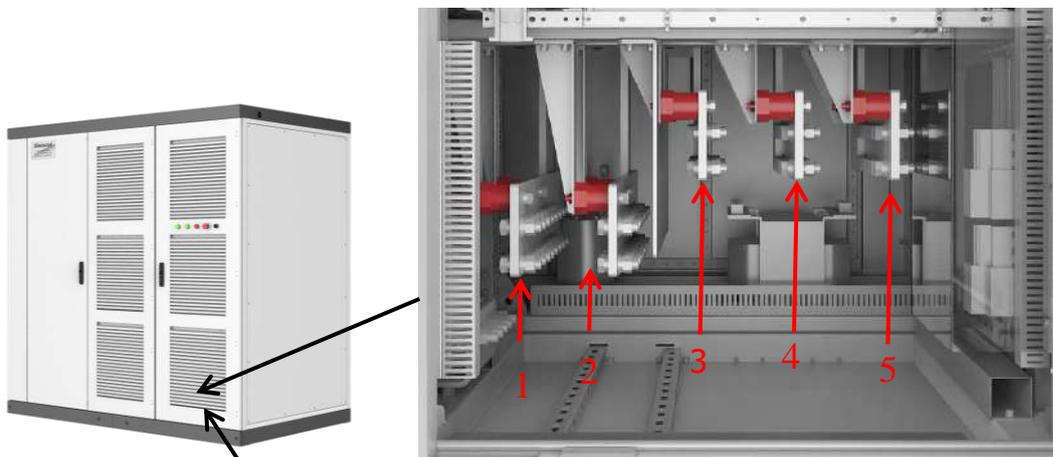

Fig. 6-5 AC & DC terminal diagram(1 branch)

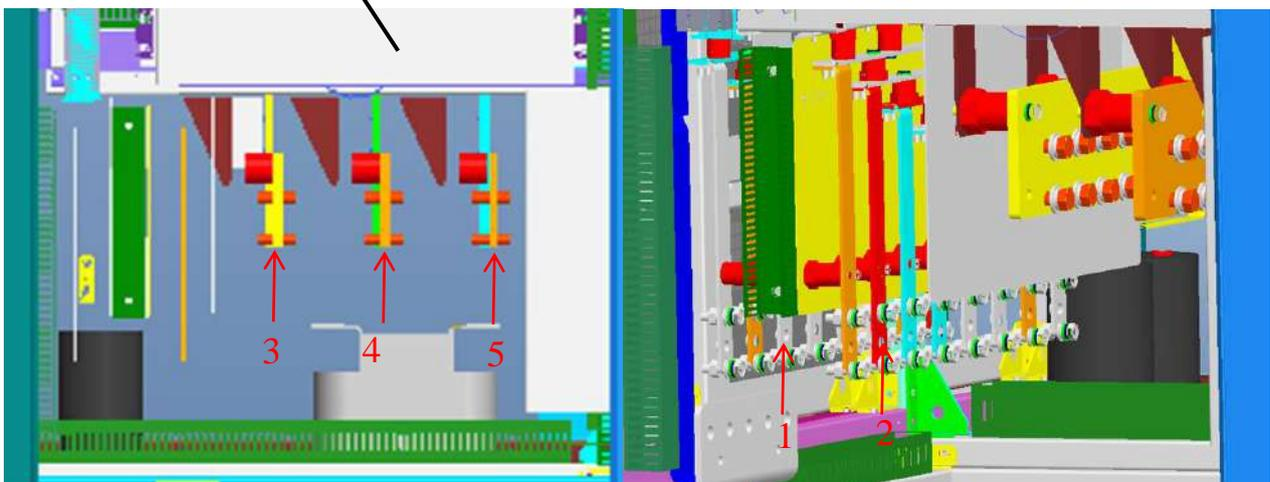

Fig. 6-6 AC & DC terminal diagram(8 branches)

Position	Designation	Description
1	Battery +	Battery input positive pole
2	Battery -	Battery input negative pole
3	L1	Phase L1
4	L2	Phase L2
5	L3	Phase L3

6.3.8 DC side wiring

Before wiring the DC side, the following check should be performed:

- Measure the open-circuit voltage of the battery/busbar set to ensure that the open-circuit voltage is within the normal DC voltage range of the energy storage converter.
- Confirm the positive and negative polarity of the cable and mark it well.



Attention

The open circuit voltage of the battery pack is strictly prohibited to exceed the maximum DC input voltage of the energy storage converter, too high open circuit voltage will cause damage to the energy storage converter.

The positive and negative terminals of the battery pack are connected to the positive and negative copper row of the energy storage converter, not to be reversed.

To connect either side of the cable, proceed as follows:

- ① Make sure that the battery or bus bar of the front stage of the energy storage converter is disconnected.
- ② Confirm that the DC disconnect switch or DC circuit breaker of the energy storage converter is open.
- ③ Peel off the insulation skin at the end of the cable, the length of the bare cable should be more than the wiring copper nose wire hole depth of about 5 mm.
- ④ Use terminal crimping machine or crimping pliers to compress the wiring copper nose.
- ⑤ Select heat shrink tubing that matches the size of the cable and use a hot air blower to shrink the tubing.
- ⑥ Fasten the DC+ and DC- cables respectively with the appropriate size bolts using a wrench.

In order to prevent the wiring copper nose loosening caused by poor contact, or to increase the contact resistance caused by local overheating or even fire, should ensure that the tightening screw to meet

the torque requirements shown in Table 6-2:

Table 6-2 Screw size and torque comparison table

Screw size	M6	M8	M10	M12	M16
Torque(N.m)	7~8	17~20	34~40	60~70	119~140

6.3.9 AC side wiring

Before wiring the AC side, the following checks should be performed:

- Measure the AC line voltage to ensure that the AC line voltage is within the normal AC voltage range of the energy storage converter.
- Confirm the phase sequence of the cable and mark it well.



Attention

Incorrect AC side wiring can cause the energy storage converter to not work properly or even be damaged. Make sure the grid-side distribution circuit breaker is disconnected and the AC and DC disconnect switches are disconnected before wiring.

If there is an "N" line tap on the machine side of the isolation transformer, the "N" line is suspended and must be well insulated, and it is forbidden to ground the "N" line.

In order to avoid cable transmission process due to uneven cable wiring and three-phase current imbalance, it is recommended that the AC cable group alignment, each group contains a three-phase cable each. The distance between the group and the group is at least two times the diameter of a single cable. And energy storage converter AC wiring side to the isolation transformer machine side winding of each phase cable length should be similar.

The AC side of the energy storage converter needs to be connected to the grid via an isolation transformer, and the steps to connect the AC cable are as follows:

- ① Verify that the grid distribution switch on the AC rear stage of the energy storage converter is off.
- ② Confirm that the AC and DC disconnect switches of the energy storage converter are both off.
- ③ Determine the phase sequence of the AC connection cable and mark it well.
- ④ Peel off the insulation skin at the end of the cable, the length of the bare cable should be more than the wiring copper nose wire hole depth of about 5 mm.
- ⑤ Use terminal crimping machine or crimping pliers to compress the wiring copper nose.
- ⑥ Select heat shrink tubing that matches the size of the cable and use a hot air blower to shrink the tubing.
- ⑦ Select the right size bolts and use a wrench to tighten the cables in phase "L1", phase "L2", and phase "L3" respectively.

6.3.10 Ground Connection



Attention

The grounding cable must be well grounded, otherwise:

- Possible fatal click hazard to the operator in case of failure.
- Possible equipment damage in the event of a lightning strike.
- May cause the device to fail to operate properly.

Before leaving the factory, the shell of the energy storage converter and the devices that need to be grounded in the cabinet have been connected reliably with the grounding copper row at the bottom of the machine. When making the grounding connection, a grounding cable with a cross-sectional area of at least 240mm² is needed to connect the PE grounding copper row reliably with the grounding row at the installation site or in the machine room, and then connect it to the earth or ground network through the equipotential connection device, and the grounding resistance shall not be greater than 4Ω.

After the cable connection is completed, the gap around the bottom of the converter should be sealed with fireproof mud. Tighten the waterproof terminals of communication cables, etc., and plug the unused waterproof terminals with suitable plugs to meet the requirements of waterproof and dustproof.

6.3.11 Wiring of terminal strips

Except power cable connection in the whole PCS, there are also auxiliary power connection, input and output of some node signals. All of them are led to the terminal strips with cluster cables in the rack. The port definition of external wiring for terminal strips is shown in Fig. 6-7 below.

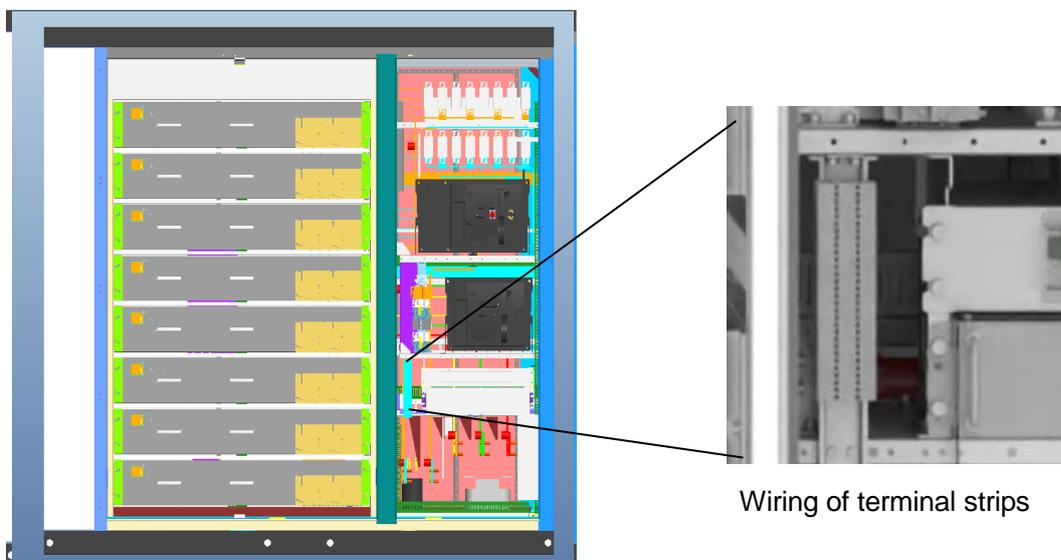

Fig. 6-7 Wring and communication interface position

Table 6-3 Definition of terminal strip ports

P1 terminal

220V AC auxiliary power supply		
	1	L
	2	L
	3	
	4	N
	5	N
External Fan control power AC220V		
	6	N
	7	L

P2 terminal(1 branch)

P2 Dry contact signal		
BMS open circuit fault	1	shorting piece
	2	
Input dry contact A	3	shorting piece
	4	
Input dry contact B1	5	shorting piece
	6	
Input dry contact B2	7	shorting piece
	8	
DC QD1 status signal	9	shorting piece
	10	
	11	
	12	

P2 terminal(multi-branches)

P2 Dry contact signal		
BMS open circuit fault	1	shorting piece
	2	
Input dry contact A	3	shorting piece
	4	
Input dry contact B1	5	shorting piece
	6	
Input dry contact B2	7	shorting piece
	8	
DC QD1 status signal	9	shorting piece
	10	
DC QD2 status signal	11	shorting piece
	12	
DC QD3 status signal	13	shorting piece
	14	

DC QD4 status signal	15	shorting piece
	16	
DC QD5 status signal	17	shorting piece
	18	
DC QD6 status signal	19	shorting piece
	20	
DC QD7 status signal	21	shorting piece
	22	
DC QD8 status signal	23	shorting piece
	24	
	25	
	26	

Note: If access is required, the shorting piece needs to be removed!

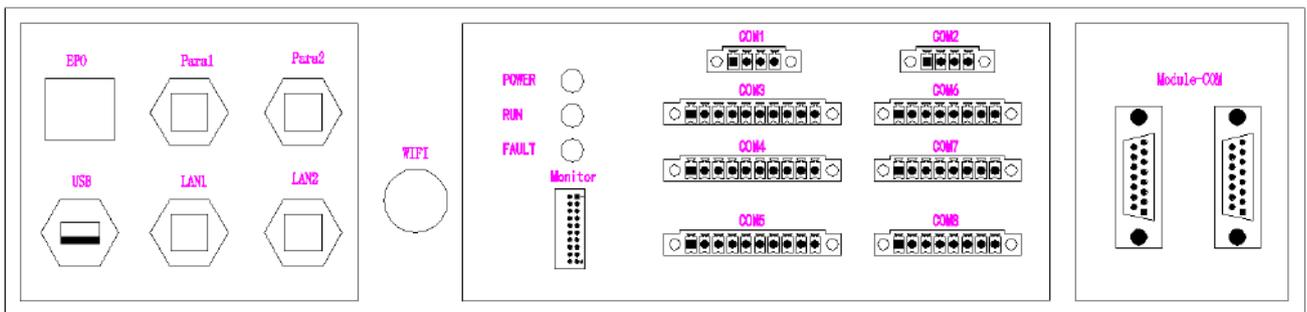

<p>J48 COM1-1 EMS-485A COM1-2 EMS-485B COM1-3 Resv-485A COM1-4 Resv-485B</p>	<p>J46 COM3-1 MON_EXT_OUT1 COM3-2 GND_SELV COM3-3 MON_EXT_OUT2 COM3-4 GND_SELV COM3-5 NC_Dry_OUTA_SELV COM3-6 DO_Dry_OUTA_SELV COM3-7 NO_Dry_OUTA_SELV COM3-8 NC_Dry_OUT6 COM3-9 DO_Dry_OUT6 COM3-10 NO_Dry_OUT6</p>	<p>J44 COM4-1 Dry_OUT1_DRV_SELV COM4-2 GND_SELV_IO COM4-3 Dry_OUT2_DRV_SELV COM4-4 GND_SELV_IO COM4-5 Dry_OUT3_DRV_SELV COM4-6 GND_SELV_IO COM4-7 Dry_OUT4_DRV_SELV COM4-8 GND_SELV_IO COM4-9 Dry_IN_OverTemp_NC_SELV COM4-10 GND_SELV_IO</p>	<p>J43 COM5-1 Dry_IN_EPO_NC_SELV COM5-2 GND_SELV_IO COM5-3 NC COM5-4 NC COM5-5 NC COM5-6 NC COM5-7 Dry_INC_SELV COM5-8 GND_SELV COM5-9 Dry_IND_SELV COM5-10 GND_SELV</p>
<p>J47 COM2-1 BMS-485A COM2-2 BMS-485B COM2-3 BMS-CANH COM2-4 BMS-CANL</p>	<p>J31 COM6-1 DC_Switch1_State COM6-2 GND_SELV_IO COM6-3 DC_Switch2_State COM6-4 GND_SELV_IO COM6-5 DC_witch3_State COM6-6 GND_SELV_IO COM6-7 DC_Switch4_State COM6-8 GND_SELV_IO</p>	<p>J32 COM7-1 DC_Switch5_State COM7-2 GND_SELV_IO COM7-3 DC_Switch6_State COM7-4 GND_SELV_IO COM7-5 DC_Switch7_State COM7-6 GND_SELV_IO COM7-7 DC_Switch8_State COM7-8 GND_SELV_IO</p>	<p>J34 COM8-1 Dry_IN_BMS_NC_SELV COM8-2 GND_SELV_IO COM8-3 Dry_INA_SELV COM8-4 GND_SELV_IO COM8-5 Dry_INB1_SELV COM8-6 GND_SELV_IO COM8-7 Dry_INB2_SELV COM8-8 GND_SELV_IO</p>

Fig. 6-8 U2 control box Wiring and communication interface position

Control Box Wiring Explained:

- 1. **EPO** is the emergency stop button;
- 2. **Para1** is parallel port 1, **Para2** is parallel port 2;

- 3. **USB** is the software update and record download interface;
- 4. **LAN1** is network port communication 1, **LAN2** is network port communication 2;
- 5. **POWER** indicates the power supply indicator, **RUN** indicates the running indicator, and **FAULT** indicates the fault indicator.
- 6. **Monitor** is the reserved port of monitor , door panel indicator, and EPO port.
- 7. **COM1&COM2** are 485 and CAN communication ports;
- 8. **COM3-COM8** are the dry contact ports.
- 9. **Module-COM** is the communication port of module.

6.3.12 Communication

When an Ethernet communication solution is selected for a single energy storage converter, only the Ethernet interface of the energy storage converter needs to be connected to the EMS system using a network cable (EIA/TIA568B).



Fig. 6-9 Schematic diagram of single PCS Ethernet communication scheme

The communication connection of multiple PCS needs to be configured with an Ethernet switch, and the communication network cables of multiple machines are connected to the same switch and then unified to the EMS system.

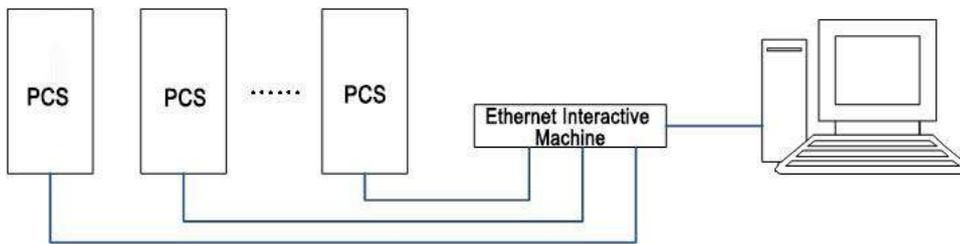

Fig. 6-10 Schematic diagram of multiple PCS Ethernet communication scheme

6.3.13 Installation checklist

After the PCS is fully installed, at least two staff members are required to conduct a comprehensive inspection of its installation in accordance with the items listed in the table below. The inspection process should be recorded, and once the entries that do not meet the requirements are found, they should be rectified immediately.

Table 6-4 Checklist

Mechanical installation inspection	
<input type="checkbox"/>	No deformation or damage to PCS
<input type="checkbox"/>	PCS bottom fixed, stable and reliable support
<input type="checkbox"/>	Sufficient space around PCS
<input type="checkbox"/>	The temperature, humidity and ventilation of the environment in which PCS is located meet the requirements

<input type="checkbox"/>	Smooth cooling air circulation
<input type="checkbox"/>	Complete and reliable cabinet sealing protection
Electrical installation inspection	
<input type="checkbox"/>	PCS grounding is complete and solid
<input type="checkbox"/>	Grid-side voltage matches PCS AC-side voltage
<input type="checkbox"/>	The net side connection phase sequence is consistent, the tightening torque meets the requirements
<input type="checkbox"/>	Battery system DC voltage matched to PCS DC side voltage
<input type="checkbox"/>	DC positive and negative polarity matched with PCS positive and negative polarity
<input type="checkbox"/>	Communication wiring is correct, and keep a certain distance from other cables
<input type="checkbox"/>	Correct and clear cable marking
<input type="checkbox"/>	Complete and reliable insulation shield, clear and firm hazard warning labels
Other inspection	
<input type="checkbox"/>	All useless conductive parts are tied with insulating ties
<input type="checkbox"/>	No tools, parts, iron filings or other foreign objects left inside the cabinet
<input type="checkbox"/>	No condensation of moisture or icing inside the cabinet

7 Product operation

7.1 Check before operation

Before the first operation or after completing maintenance and overhaul, the installation of the equipment should be thoroughly checked again.



WARNING

All operations during operation must be performed by professional electrical personnel, and no individual may operate without authorization.

7.1.1 Check cable connections

- Check all connection cables for tears or cracks and make sure that all connection cables are intact.
- Double-check that all cables are connected correctly against the system wiring schematic.
- Make sure that all cables are securely connected.
- Confirm that the cabinet grounding point is well connected to the grounding point of the foundation.

Each grounding inside the cabinet is normal. Grounding resistance shall not be greater than 4Ω.

7.1.2 Check the PCS

- Make sure the main circuit AC and DC disconnect switches are all disconnected.
- Make sure the emergency stop knob has been released and can work normally.
- Check and ensure that the electrical switches and buttons of the energy storage converter and the front and rear stages are flexible and meet the specification requirements.
- Make sure the DC auxiliary source disconnect switch QS3 stays ON, AC auxiliary source disconnect switch QS1 stays ON, and fan AC auxiliary source disconnect switch QS2 stays ON.
- Note that AC auxiliary source disconnect switch QS1 and AC auxiliary source external power supply switch QF1 are strictly prohibited to be closed at the same time!
- Note that the fan AC auxiliary source isolation switch QS2 and the fan AC external power supply switch QF2 are strictly prohibited to close at the same time!

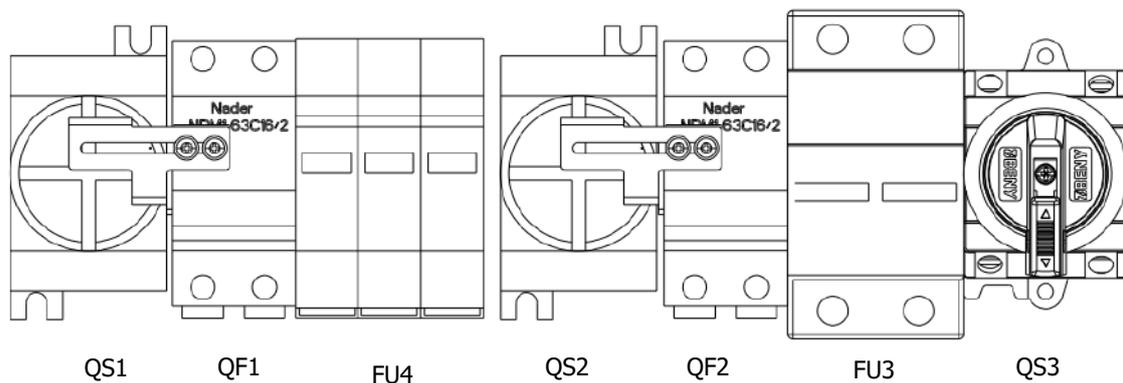

Fig. 7-1 Disconnect switch position diagram

7.1.3 Check the Battery/Grid Side Voltage

- Measure the open-circuit voltage of each energy storage battery for compliance and record it accurately.
- Make sure the positive and negative polarity is correct.
- Measure the resistance of the cable between the battery pack junction box and the machine using an ohmmeter with a megohm range and record it accurately.



Make sure that the measuring device is used correctly, otherwise there is a danger of clicking.



WARNING

The voltage on either side shall not exceed the maximum DC voltage allowed by the energy storage inverter,

Excessive DC voltage can damage equipment or even cause safety accidents.

- Accurately measure the three sets of line voltage on the AC grid side, the measured value should not exceed the allowable grid voltage range on the AC side of the energy storage converter, and the three phases are balanced.
- Accurately measure the AC grid side frequency, the measured value should not exceed the allowable grid frequency range of the AC side of the energy storage converter.
- It is recommended to measure the THD (Total Harmonic Distortion) of each phase voltage. If the distortion is severe, the energy storage inverter may not operate.

7.2 Power on and shut down

7.2.1 Power on

After all the above checks before operation meet the requirements, close the cabinet door of the energy storage converter, pull out the cabinet door key and hand it over to a person for proper storage, then the energy storage converter can be switched on. The operation steps are as follows.

- ① Close the battery cabinet output switch. The DC port of the equipment is powered on, the green "power indicator" is always on, after about 10 seconds, the red "fault indicator" flashes, and the webpage background menu "event log" - "current warning" page shows the "Current Warning" page shows "AC Under Frequency" and "AC Under Voltage" warning information.
- ② Set the working mode. The default working mode of energy storage converter is "grid-connected" after power on, if you want to work off-grid, please change it through the host computer.
- ③ If the setting mode in step 3 is "off-grid", the "fault indicator" should be extinguished after the setting is finished and the warning message in "current warning" will disappear. If the setting mode in step 3 is "grid-connected" and the grid-side distribution circuit breaker is closed, the "fault indicator" shall go off after the circuit breaker is closed and the warning message in the "current warning" shall disappear.
- ④ The energy storage converter starts working according to the dispatching instruction.

The default power-on mode of the energy storage converter is "automatic". After the AC and DC are

powered on, it will automatically and continuously monitor whether the AC and DC side voltage and other parameters meet the operation requirements. If all the parameters on AC and DC sides meet the conditions, the converter will be automatically turned on and run according to the dispatching instruction.

7.2.2 Shut down

Shut down is usually divided into two cases: shutdown during normal maintenance or overhaul and shutdown during emergency.

For shutdown during normal maintenance or overhaul, operate according to the following steps.

① Control the shutdown of the energy storage converter through the control command "shutdown" from the host computer.

② Disconnect the battery cabinet output switch.

③ Disconnect the AC side distribution circuit breaker.



The internal capacitor of the energy storage converter stores dangerous energy, and maintenance or overhaul is strictly prohibited within 15 minutes after the end of the execution of the shutdown operation.



During normal operation of the equipment, manual disconnection of the AC/DC disconnect switch is strictly prohibited.

To avoid the danger of arcing damage to the disconnect switch, which may also lead to equipment damage in serious cases.

To shut down in case of emergency, operate according to the following procedure.

① Press the emergency stop button.

② Disconnect the battery cabinet output switch.

③ Disconnect the bus side distribution circuit breaker.



The emergency stop button is for emergency use only. The normal shutdown should be done through the "shutdown" operation command of the host computer.

In case of emergency, be sure to press the emergency stop knob directly to ensure rapid shutdown.

7.3 Operating mode

7.3.1 Main Function

The PWS1-1725KTL-H energy storage converter has the following functions.

- Local manual

The energy storage converter is subject to local monitoring or web monitoring for switch-on/off charging and discharging operation, and is subject to local scheduling.

- Local automatic

The energy storage converter is operated by the automatic operation strategy set by the local monitoring or web monitoring, and is scheduled by the local strategy.

- Remote control

The energy storage converter accepts remote scheduling commands, at this time there is no local scheduling and operation authority. It is required to login and change the control mode.

- On/off-grid control

The energy storage converter can work in on-grid and off-grid modes. In on-grid mode, the AC side follows the grid voltage. In off-grid mode, PCS outputs constant frequency and constant voltage AC power.

- Charge and Discharge Control

The energy storage converter is capable of charging and discharging the battery pack. The charging power and discharging power can be selected by the user. The various modes of charging and discharging commands are modified by the host computer.

The charging modes include pre-charge, equalize charge and float charge, and the equalize charge can be set to constant current charge and constant power charge.

Discharge modes include constant current discharge and constant power discharge.

- Reactive power control

The energy storage converter is capable of controlling the power factor and reactive power ratio. The energy storage converter is capable of this function when performing both charging and discharging functions. The user can set the reactive power via the host computer.

- Output voltage and frequency stabilization

The energy storage converter can adjust the output voltage and frequency stabilization by controlling the reactive power and active power in the on-grid system. To realize this function, a large-scale energy storage plant is required.

7.3.2 Operating status introduction

PWS1-1725KTL-H energy storage converter has several states such as "initial stop", "stop", "running", "standby", "fault", "emergency stop" and so on.

- Initial stop

In this state, the system performs a self-test. When the self-test is passed, the converter is transferred from

the initial shutdown mode to the shutdown mode.

- Shutdown

When the energy storage converter does not receive any operation command or dispatch, the system is in shutdown mode.

In shutdown mode, the converter receives operation instructions and scheduling from the host computer, and when the operating conditions for operation are met, the equipment is transferred from shutdown to operation mode.

During operation, if a "shutdown" command is received, the energy storage converter is transferred from operation to shutdown.

- Running

The running mode is divided into charging and discharging.

- Standby

In this state, the AC and DC contactors of the energy storage converter are closed and the internal auxiliary power supply of the machine is in working condition, ready to respond to the operating commands as fast as possible.

- Fault

PWS1-1725KTL-H energy storage converter has a comprehensive fault detection function, and the fault type can be divided into two categories: "shutdown fault" and "non-shutdown fault". When "shutdown fault" occurs, the system enters the shutdown state; when "non-shutdown fault" occurs, the webpage of the energy storage converter issues alarm information in the background, but does not stop the operation state.

- Emergency shutdown

When the emergency stop button is pressed at the critical moment, the equipment enters the emergency stop state, and when it needs to enter the operation state again, the emergency stop knob must be turned.

7.3.3 Operating State Switching

When the energy storage converter is powered up into initial shutdown, the control system will complete a self-test to verify the integrity of the entire sensor system. the DSP starts normally and the energy storage converter enters shutdown.

PWS1-1725KTL-H series energy storage converters can be switched between different modes, and the switching conditions that need to be met are shown in Fig. 7-2.

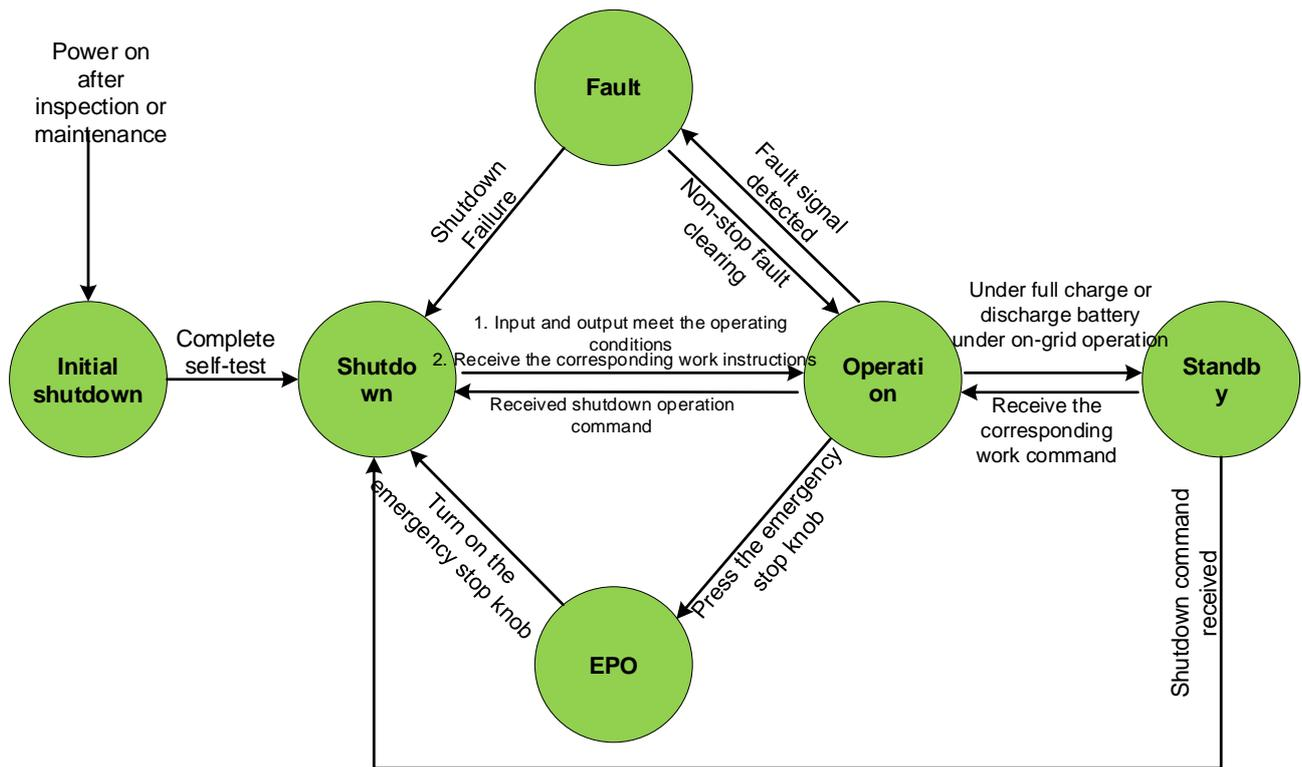

Fig. 7-2 Switching between different working states

The operating modes of the energy storage converter can be divided into grid-connected charging, grid-connected discharging, off-grid charging and off-grid discharging. Whether in grid-connected or off-grid mode, the charging and discharging conversion can be carried out directly, while the conversion of grid-connected and off-grid mode needs to go through the shutdown state.

7.4 Protection Function

PWS1-1725KTL-H series energy storage converters have all-round protection function, which can effectively operate when the battery side voltage or grid side voltage is abnormal, and protect the safe operation of energy storage converters until the abnormal condition disappears, and then continue to generate electricity to the grid. Protection items include but not limited to

- DC over/undervoltage protection

When the DC voltage of the energy storage battery exceeds the allowable voltage range, the energy storage converter will stop working, and at the same time send an alarm signal and display the fault type on the web page.

- Grid Over/Under Voltage Protection

When the grid voltage exceeds the operating voltage range, the energy storage converter stops working, an alarm signal is issued and the type of fault is displayed on the back panel of the web page.

- Grid over/under frequency protection

When the energy storage converter detects that the grid frequency fluctuation exceeds the allowable range, the energy storage converter will stop working, and at the same time issue an alarm signal and display the fault type on the webpage.

- Islanding protection

When the energy storage converter detects that the effective value of the grid voltage drops below 30% of

the rated value, or the grid frequency can be disturbed by the converter, the energy storage converter will stop working, and at the same time issue an alarm signal, and display the fault type on the web page.

- AC short circuit protection

When a short-circuit fault occurs on the AC side of the energy storage converter, the converter will stop working, send an alarm signal and display the type of fault on the webpage.

- IGBT over-temperature protection

The IGBT module of the energy storage converter uses a high-precision temperature sensor, which can monitor the module temperature in real time. When the temperature is too high, the DSP will issue a command to stop the operation of the energy storage converter, and at the same time issue an alarm signal and display the type of fault on the web page.

- Environmental over-temperature protection

When the temperature is too high, the DSP will issue a command to stop the operation of the energy storage converter, send an alarm signal and display the fault type on the web page.

- AC voltage imbalance

When the energy storage converter detects that the difference between the three phase AC voltage is out of the allowable range, the energy storage converter will stop operation, and at the same time issue an alarm signal and display the fault type on the web page.

- Phase abnormality

When the energy storage converter detects an error in the phase of the three phases of the connected grid during the initial shutdown, shutdown or fault self-test, the energy storage converter will issue an alarm signal and display the fault type on the web page.

- Sampling zero failure

When the energy storage converter detects that the zero deviation value of the sampling channel is out of the allowed range during the self-test, the energy storage converter will issue an alarm signal and display the fault type on the web page. After restoring to normal, the energy storage converter should be re-powered for self-test and pass it before normal operation.

- Reverse polarity fault

When the energy storage converter detects a negative DC voltage during the self-test, the energy storage converter will issue an alarm signal and display the fault type on the webpage. After restoring to normal, the energy storage converter should be re-powered for self-test, and it can work normally only after passing.

Note: Short-circuiting the device when in the process of power-on operation may lead to damage to the internal devices of the device.

When the above fault occurs, the energy storage device will go into protection shutdown, when the fault is restored, according to the type of fault, it is divided into automatic reset, manual operation reset (fault clearing command), and down power reset.

8 Network Monitoring Introduction

8.1 Web backend functions and menu introduction

PWS1-1725KTL-H supports webpage backend interaction, which is convenient for users to view data and perform related operations. Users can connect to the energy storage converter through via LAN cable.

Afterwards, open the web browser and enter the IP address of the energy storage converter: 10.10.10.1 to

enter the login interface of the web backend, as shown in the following figure.

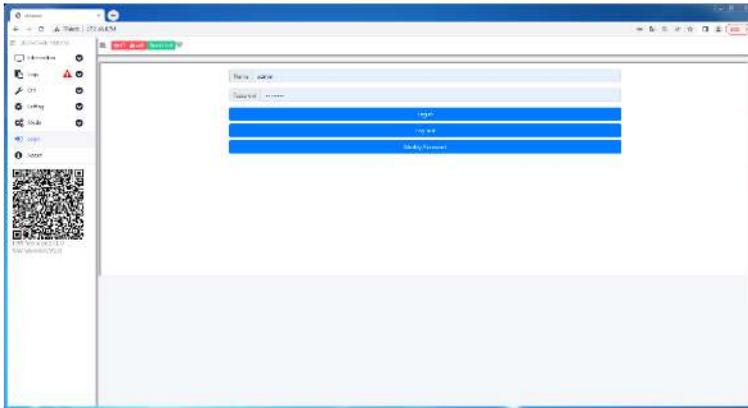

Web backend login page

Login username: admin, the initial password is 123456, it can be modified in the "Login - Change Password" page.

Users can enter the webpage backend after entering the correct user name and password, which is convenient for issuing various operation commands, viewing various operation-related parameters and working status, obtaining the current working condition of energy storage converter and alarm information in time, and displaying the version information of system control software and internal monitoring software.

8.2 Network monitoring initial state description

The web-based monitoring system of PWS1-1725KTL-H can be connected directly through the network cable or connected to the LAN for remote monitoring and control.

System network port communication address default state:

LAN 1: 192.168.1.10

LAN 2: 172.16.1.10

8.3 LAN port connection

Take control box LAN2 as an example.

The PC is directly connected to the control box LAN port, and the PC port is configured with IPv4 manual settings so that the PC and the control box are in the same network segment:.

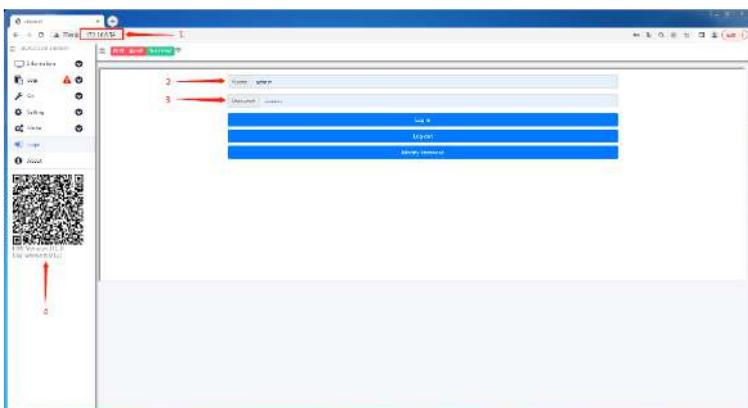

1. type the IP address of the device in the browser.
2. type username.
3. Type password 123456
- (4. QR code for product information)

Find the monitoring setting in the setting item, IP address can be set as the IP in the LAN segment that the current device can access, pls note not to conflict with the existing IP; the current web communication will be lost after typing, the control box can transfer to the LAN, and the computer can access the LAN for remote connection (Note: type newly set IP).

8.4 the operation information menu introduction

After the user enters the correct user name and password and enters into the backend of the web page, then enters the secondary menu display screen of the operation information by clicking on the operation information. There are multiple pages in the secondary menu interface, here just take home screen for reference, and the contents of other pages are listed in full in the description section.

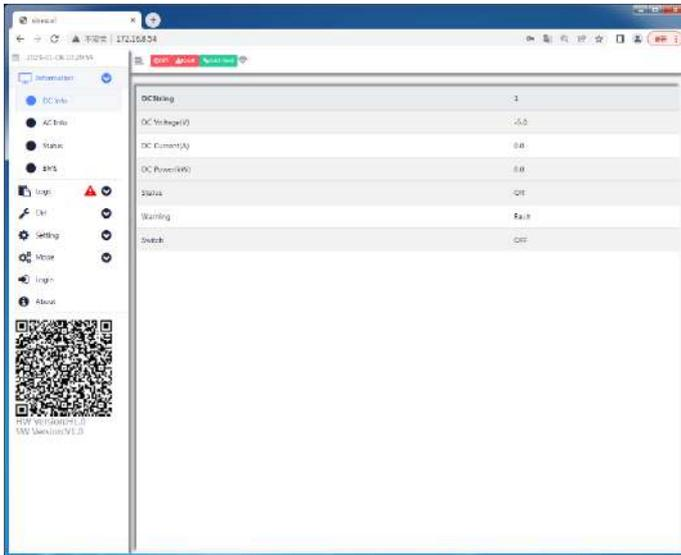

DC information secondary submenu

Display equipment DC voltage, DC current, DC power, bus voltage, operation status, alarm status and working status.

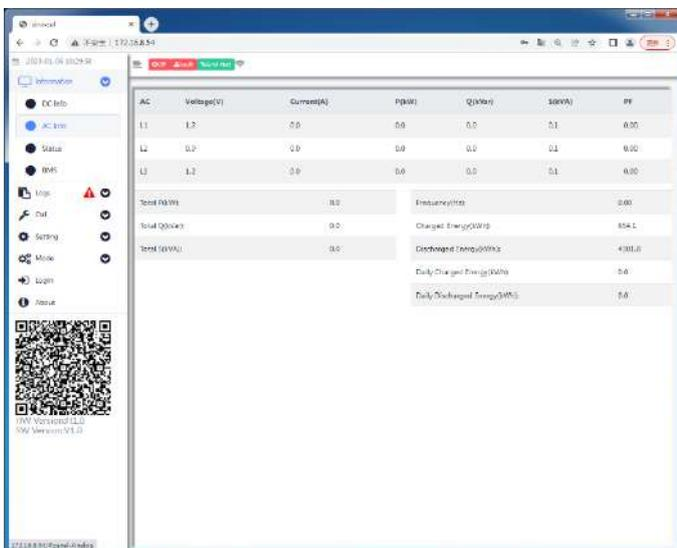

AC information secondary submenu displays

instantaneous three-phase voltage, instantaneous three-phase current, instantaneous active power, instantaneous reactive power, instantaneous apparent power, instantaneous power factor, instantaneous frequency, as well as the accumulated active charging power capacity and active discharging power capacity so far.

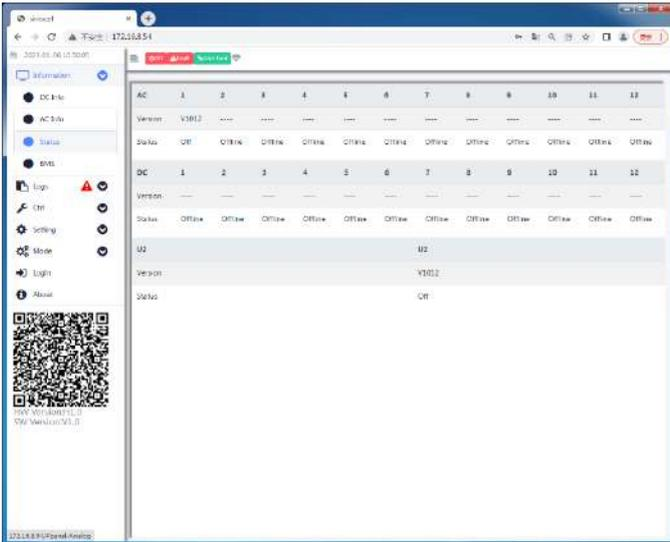

Module information secondary submenu
Display module operation status, version number.

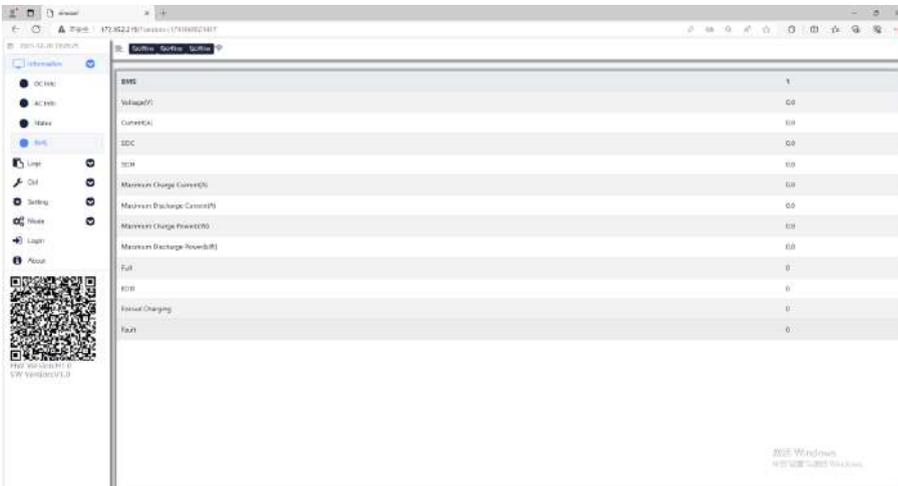

BMS information secondary submenu displays battery-related voltage,current,SOC,and charge/discharge status information, etc.

8.5 Event Logging Menu Introduction

Click the Event Logging menu to enter the secondary menu display screen for event logging. When there are multiple pages in the secondary menu screen, only the first page screen is displayed in this subsection, and the contents of other pages are listed in full in the description section.

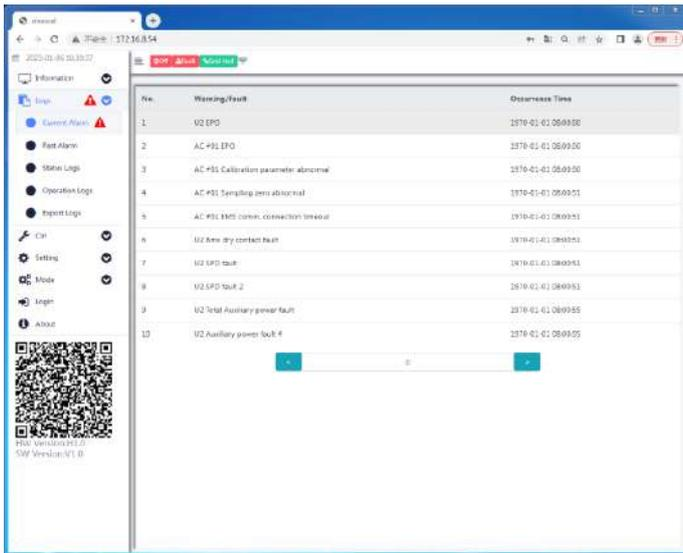

Alarm happens on secondary submenu
Displays various alarm messages that exist in the current situation.

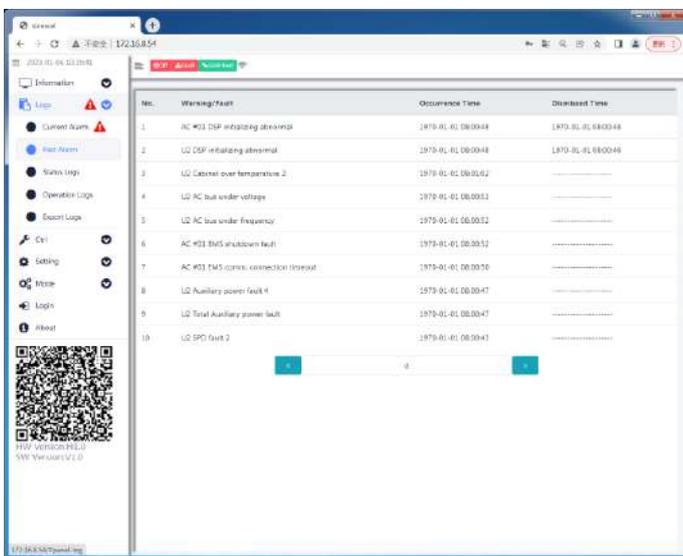

History Alarms secondary submenu
Displays various alarms had appeared before, but have been cleared in the current case.

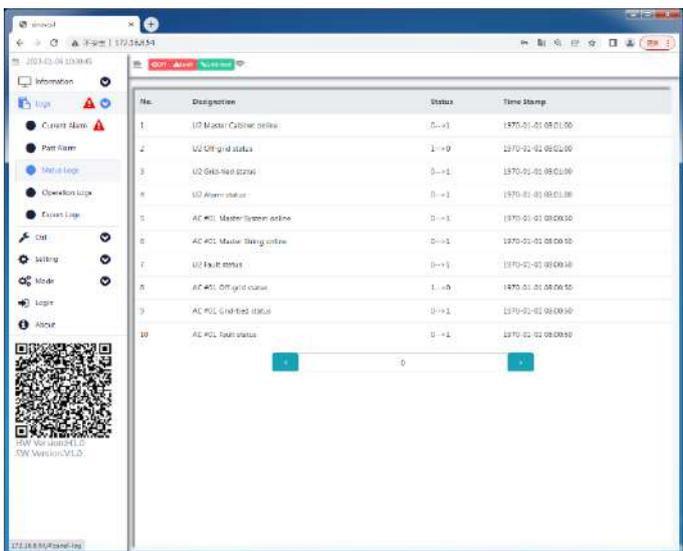

Status log secondary submenu
Displays the status change log of the PCS.

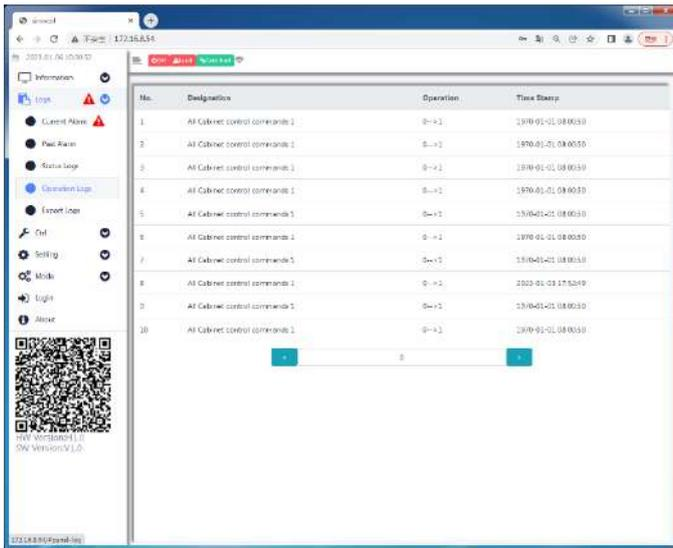

Operation log secondary submenu
Displays the log of commands issued to the PCS.

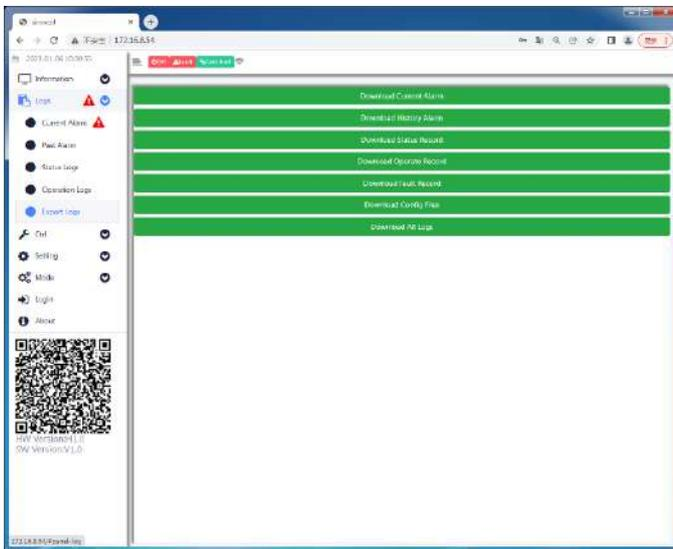

Record Export secondary submenu
Provides downloading of all record files to the local browser download directory.

8.6 Introduction to control & dispatching menu

Click the control & dispatching menu to enter the secondary submenu to set control and dispatching commands.

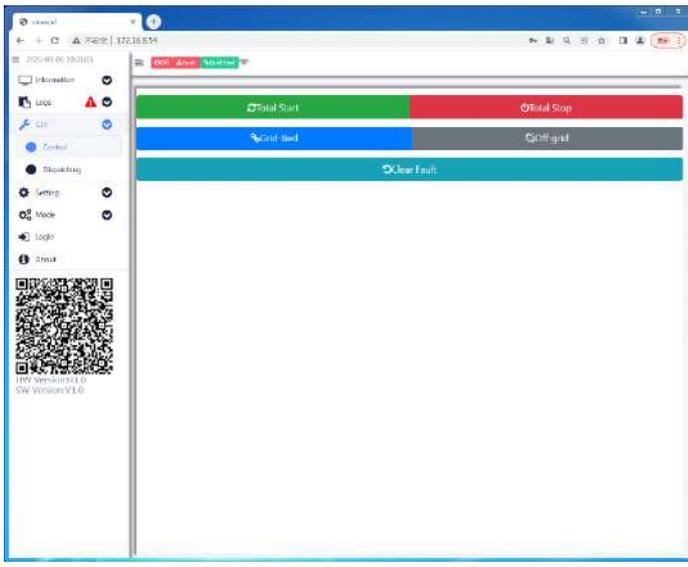

Control command secondary submenu can control the PCS's power on, power off, grid connection, off-grid and fault reset functions (note that the fault reset function should not be used arbitrarily).



Dispatching commands secondary submenu

Users can set energy dispatching mode, active control mode, reactive control mode, active power regulation, reactive power regulation and power factor setting for energy storage converters.

Energy dispatching: AC dispatching and DC dispatching can be selected

AC dispatching: active control mode, reactive control mode, active power regulation, reactive power regulation and power factor setting can be set

DC dispatching: DC control mode, DC power regulation and DC current regulation can be set.

8.7 Introduction to the settings menu

Clicking on the System Setup menu will lead you to the secondary submenu of System Setup, including System Setup, Monitor Setup, and DC Setup.

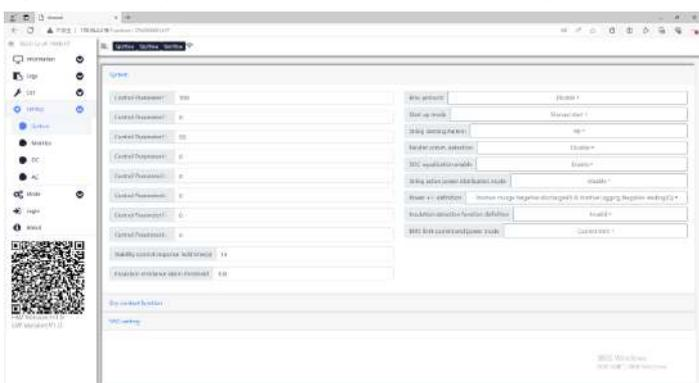

System setting secondary sub-menu

This interface is customized interface, if necessary, please contact our engineers for relevant settings

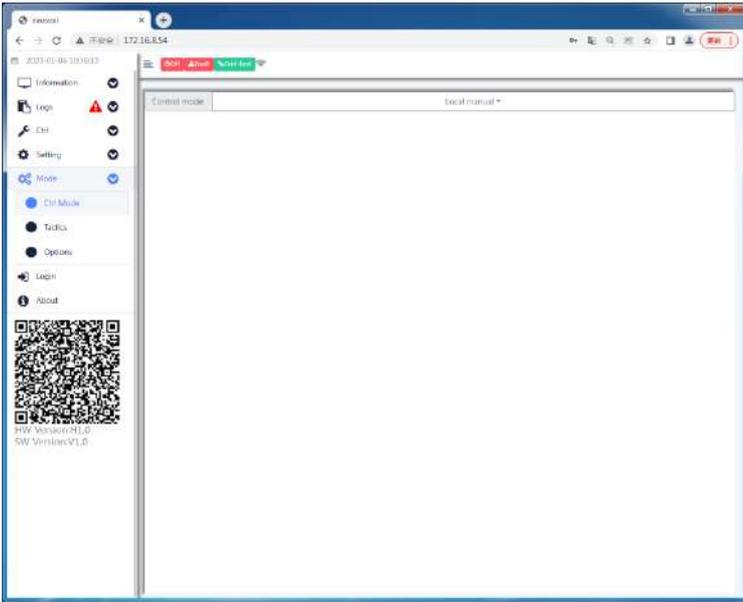

Operation mode secondary submenu

Users can set the operation mode of the PCS: local control, local automatic and remote control.

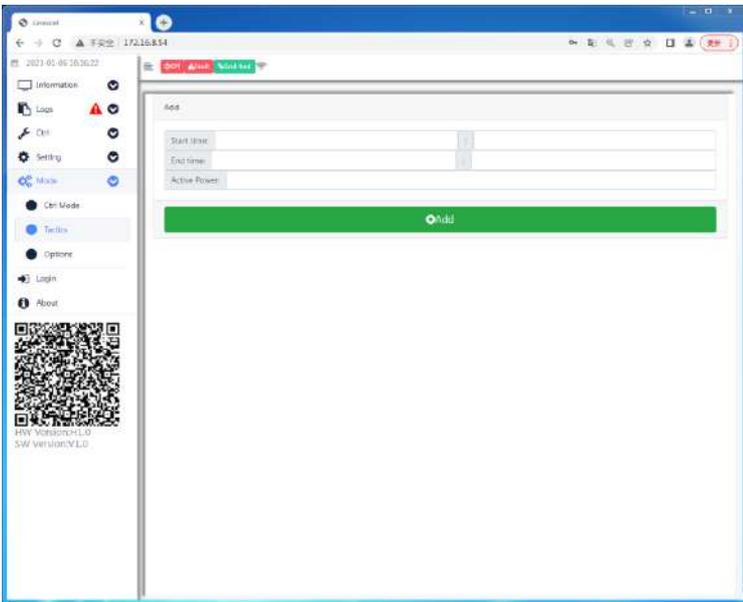

Strategy secondary submenu

Users can set the charging and discharging status at different times of the day and the corresponding charging and discharging power.

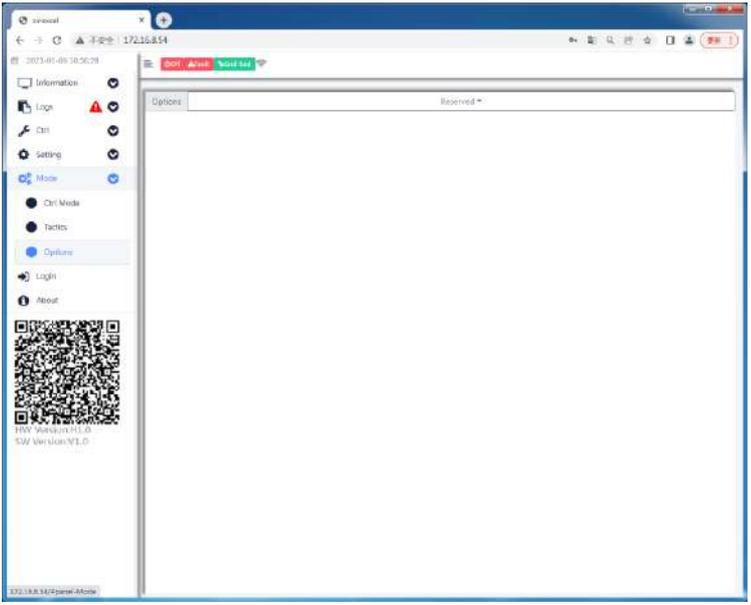

Options secondary submenu
 Users can set up reservation, insulation detector, grid meter, and PV DCDC.

8.9 Introduction to Login Menu

Click Login Menu to enter the login menu screen.

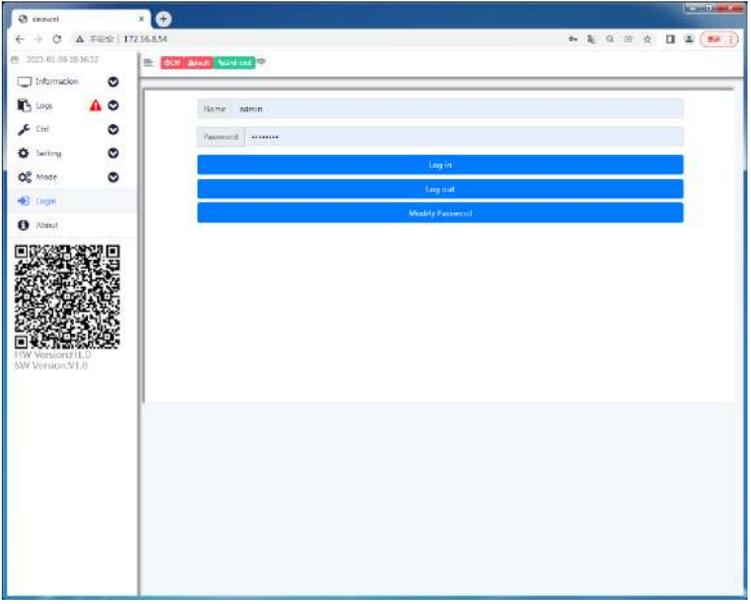

After successful login, users can log in and log out with more advanced privileges and change their passwords in this screen.

8.10 Introduction to About this machine menu

Click About this machine menu to enter the menu screen.

9.2 LED Indicator light display and troubleshooting methods

Please refer to the following table for device status descriptions:

Fig. 9-1 troubleshooting methods

LED status	troubleshooting methods
POWER Indicator light not light up	<p>It means that the PCS rack auxiliary source is powered down, and the troubleshooting method is as follows.</p> <ol style="list-style-type: none"> 1. Ensure that both the AC side and DC side of the PCS are energized and the voltage is normal. 2. Check whether Q1 and QS1, QS1 and QS3 are in closed state, and whether the fuse core of FU3 is intact. 3. If the power indicator is still off after the above checks, please contact our service personnel.
RUN Indicator light not light up	<p>It means that the PCS is not in running working condition</p> <ol style="list-style-type: none"> 1. Whether the system is in the power-on state; 2. Whether the system fault indicator is not in the normally lit state, or whether the system has any alarms. If so, please refer to 9.3 below for troubleshooting. 3. If after the above checks, the operation indicator is still off, please contact our service personnel.
FAULT Indicator light always on	<p>It means that the PCS is malfunctioning and the fault has not been removed.</p> <ol style="list-style-type: none"> 1. Please check the detailed fault information on the LCD screen or webpage monitor and take appropriate troubleshooting measures. 2. If the indicator still does not light up, please contact our service staff.

9.3 Common faults and Troubleshooting methods

Fault type	Possible causes	Simple handling	Remark
DC input overvoltage	DC voltage is higher than the maximum allowable DC voltage	<ol style="list-style-type: none"> 1. Check the configuration of the energy storage battery. 2. Check whether the battery voltage is abnormal, if the battery voltage exceeds the maximum topping charge value, the battery is faulty. 3. Check the protection parameters of DC setting. 4. If after the above troubleshooting, the fault is still reported, please contact our service staff. 	Contact energy storage battery supplier
DC input undervoltage	DC voltage is lower than the minimum allowable DC voltage	<ol style="list-style-type: none"> 1. Check the configuration of the energy storage battery. 2. Check whether the battery 	Contact energy storage battery supplier

			<p>voltage is abnormal, if the battery voltage exceeds the maximum topping charge value, the battery is faulty.</p> <p>3. Check the protection parameters of DC setting.</p> <p>4. If after the above troubleshooting, the fault is still reported, please contact our service staff.</p>	
AC busbar overvoltage	Grid voltage is higher than the maximum allowable grid voltage	Check the grid		After the grid voltage is restored to the allowable range, it can be re-allowed.
AC bus undervoltage	Grid voltage below the minimum allowable grid voltage	Check the grid		After the grid voltage is restored to the allowable range, it can be re-allowed.
AC bus overfrequency	Grid frequency is greater than the maximum allowable grid frequency	Check the grid		The grid can be manually re-connected after the grid frequency is restored to the allowable range
AC bus underfrequency	Grid frequency is less than the minimum allowable grid frequency	Check the grid		The grid can be manually re-connected after the grid frequency is restored to the allowable range
Island protection	The PCS detects the occurrence of island phenomenon	Check whether the grid is disconnected, and whether the voltage sampling is abnormal.		The grid can be manually re-connected after the grid frequency is restored to the allowable range
AC bus overload timeout	There is a short circuit at the AC side of the PCS or the internal electronic components are damaged	Troubleshoot whether the external load is too large, and then troubleshoot whether an internal component problem is causing the AC output current to be too large.		Contact Sinexcel
Ambient over-temperature fault	PCS internal temperature is higher than the allowable value	Check if the current ambient temperature is high, then check if the air ducts are blocked and if the fans are operating normally.		If the fault occurs more than 10 times a day, please contact Sinexcel
Module overtemperature fault x(x=1~2)	IGBT module radiator temperature is higher than the allowable value	Maintain the cooling fan after the PCS is completely powered off		If the fault occurs more than 10 times a day, please contact Sinexcel
AC electronic control switch hardware failure	The contactor connected to the power grid inside the equipment fails	Check and repair the contactor after the equipment is completely disconnected		If the fault occurs more than 10 times a day, please contact Sinexcel
DC input electric control switch open circuit	The DC disconnecter connected to the battery inside the equipment is faulty	Refer to the troubleshooting excel sheet.		If the fault occurs more than 10 times a day, please contact Sinexcel
DC input soft start failed	The soft start contactor connected to the battery inside the equipment is	Refer to the troubleshooting excel sheet.		If the fault occurs more than 10 times a day, please

	faulty		contact Sinexcel
DC fuse fault	DC side fuse failure	Refer to the troubleshooting excel sheet.	Contact Sinexcel
Lightning arrester fault	AC side lightning arrester fails	Refer to the troubleshooting excel sheet.	Contact Sinexcel
Auxiliary power failure	DC auxiliary power board is abnormal	Refer to the troubleshooting excel sheet.	Contact Sinexcel



Error classification:

Fault - hardware shutdown failure;

Alarm - Shutdown alarm;

Warning - Alarm but not shutdown.

Alarm clearing mode:

Auto - the alarm is cleared automatically after the cause of the alarm disappears;

Manual - the alarm is cleared only after the cause of the alarm disappears and a reset command is sent;

PowerOff - the alarm is cleared only after a power failure and reboot.

The following is simplified to:

Fault Shutdown + Automatic	F.A
Fault Shutdown + Manual	F.M
Fault Shutdown + Power Off	F.P
Alarm shutdown + automatic	A.A
Warning + automatic	W.A
Warning+Manual	W.M

9.4 Other faults

- The PCS works noisily

Possible causes: abnormal operation of energy storage converter and inductor or the cooling fan is faulty.

Solution:

1/check whether the power is within the normal range, and measure whether the grid-connected current and voltage waveforms are normal. If power is not normal, contact electrical personnel. If power is normal, it is recommended to turn off the machine and contact Sinexcel's personnel.

2/Repair or replace the cooling fan.

- The upper computer cannot communicate

Ethernet communication mode

1. Check whether the IP address, subnet mask and gateway are set correctly.
2. Check whether the communication cable is properly connected.

10 Maintenance

Due to the influence of ambient temperature, humidity, dust and vibration, the internal components of the energy storage converters might be aging and unable to operate properly, which leads to potential failures. Therefore, it is necessary to carry out routinely and progress regular maintenance of the energy storage converters to ensure the operation and life-expectancy.

10.1 Securities & Cautions



Warning

Only qualified and authorized personnel are allowed to perform the maintenance.

Do not leave metal parts such as screws and washers in the energy storage converter when carrying out maintenance work, otherwise there is a risk of damaging the equipment.



Warning

Before starting formal maintenance, not only should the AC/DC disconnect switch be disconnected, but also the battery cabinet switch and the grid side distribution switch should be off.

If only the DC switch is off, the copper bar of the DC cable at the bottom of the converter is still charged.



Warning

After disconnecting the DC switch/breaker, please wait at least 15 minutes before performing maintenance operations.



Warning

Please refer to the precautions mentioned in section 6.3 when electrical connections are involved in the maintenance process.

10.2 Maintenance cycle

The recommended routine maintenance intervals and work contents are shown in Table 11-1.

Inspection content	Method	cycle
software data	<ul style="list-style-type: none">● Read data from the webpage backend software● Save operational data, parameters and logs to relevant files● Check the parameter settings	Once/month
Operating status/ambience of the	<ul style="list-style-type: none">● Observe whether the converter is damaged or deformed● Check each variable for abnormalities while the system is running	Once/6 months

system	<ul style="list-style-type: none"> ● Check if the main devices are normal ● Check whether the system heat generation is normal by using thermal ● Check the ventilation system Check whether the humidity and dust of the equipment operating environment meet the requirements, and whether all air inlet filters function normally Attention! Must check the ventilation of the inlet and outlet 	
System cleaning	<ul style="list-style-type: none"> ● Check the cleanliness of the circuit board and components ● Check the heat sink temperature and dust. If necessary, use compressed air and turn on the fan to clean the module 	Once/6-12 months (depends on the working ambience)
Power Circuit Connection	<ul style="list-style-type: none"> ● Check the power cable connection for looseness ● Check the power cable and control cable, especially the cover in contact with the metal surface ● Check the wrap of the power cable terminals 	6 months after the first commissioning and after that, once per 6 to 12 months
Terminals, wire connections	<ul style="list-style-type: none"> ● Check the looseness of the screws and the terminals ● Check if the main circuit terminals (poor contact, trace of overheated) Check whether there is a color change in the wiring copper bar ● Visual inspection of equipment terminals and other connections as well as line distribution 	Once/year
Cooling fan maintenance and replacement	<ul style="list-style-type: none"> ● Check whether there are cracks in the fan blades ● check the fan is operated properly without abnormal vibration/sounds ● If so, please progress the replacement 	Once/year
Switches / Circuit Breakers Maintenance	<ul style="list-style-type: none"> ● Check all metal components for rust and corrosion ● Annual inspection of isolation switches (auxiliary switches and micro-switches) to ensure that they are in good mechanical operation ● Check operating parameters (especially voltage and insulation) 	Once/6-12 months
Security Features	<ul style="list-style-type: none"> ● EPO ● Simulating shutdown and check the signal from the communicator ● Check the warning signs, replacement should be progressed if they are damaged 	Once/6-12 months
Software maintenance	<ul style="list-style-type: none"> ● Optimize the software ● Check all parameter settings 	Once/6-12 months



Warning

Regularly check whether the fan of the cabinet module is running properly, and also observe whether there is friction sound when running, if so, it may be caused by dust and you need to stop the converter to clean the dust.

Due to the dangerous electrical energy stored in the DC bus capacitor, you need to wait at least 15 minutes after the storage converter is completely disconnected. Before removing the dust, please use a multimeter to measure and confirm that the machine is completely discharged internally to prevent electric shock.



Attention

The majority of maintenance work can only be performed by removing the protective grille inside the machine. At the end of all maintenance work, be sure to restore all the covers to their original position and ensure that all screws are tightened.

10.3 Electronic components replacement



Attention

When replacing the electronic components in the converter, please make sure to replace the components within the same manufacturer. The model number of the component is usually available through the name plate, if not, please contact Sinexcel for further assistance.



Attention

If the components need to be replaced within other manufacturers or different models of the same manufacturer, it must be confirmed by Sinexcel in advance. Otherwise, we will not be responsible for any casualties or property damage that may be caused.

11 Appendix

11.1 Quality Assurance

Sinexcel (hereinafter referred to as the Company) will repair or replace the product with a new one free of charge if the product fails during the warranty period.

- Evidence

Our company requires the customer to present the invoice and date of purchase of the product during the warranty period. Also the trademark on the product should be clearly visible, otherwise it has the right not to be quality assured.

- Conditions

The replaced non-conforming products shall be disposed of by our company.

The customer shall allow reasonable time for the Company to repair the faulty products.

- Liability Exemption

The Company shall have the right not to guarantee the warranty if the following conditions occur.

1. The whole machine or parts have exceeded the free warranty period.
2. Transport damage.
3. incorrect installation, modification or use.
4. Operation in very harsh environments beyond those described in this manual.
5. Equipment failure or damage caused by installation, repair, alteration or disassembly by non-service personnel of our company.
6. Equipment failure or damage caused by the use of non-standard or non-Sinexcel components or software.
7. Any installation or use beyond the scope specified in the relevant international standards.
8. Damage caused by abnormal natural environment.

Product failure caused by the above circumstances, the customer requests for repair service. After the determination of our service department, we can provide paid repair service.

In order to continuously improve customer satisfaction, our products and user manuals are under continuous improvement and upgrading. If there is a difference between the user manual and the product in your hands, it may be due to the version, please refer to the specific product. If you still have questions, please contact our company.

11.2 HMI Protection Parameter Setting Introduction

Table 11-1 DC protection parameters

DC control mode	Can be selected between "constant current mode" and "constant power mode".
Charge and discharge current	It can be set from -3200.0A to 3200.0A, negative value means discharge, positive value means charge, and the default value is 0.0.
Charging and discharging power	Can be set between -3200.0kW~3200.0kW, negative value means discharge, positive value means charge, default value is 0.0.
Maximum charging current	Can be set between 0~3200.0A, the default value is 5.0.
Maximum discharge current	Can be set between 0~3200.0A, the default value is 5.0.
Battery lower limit voltage	Can be set between 600.0~1500.0V, the default value is 600.0.
End-of-discharge voltage	Can be set between 600.0~1500.0V, the default value is 600.0.
Topping charge voltage	Can be set between 600.0~1500.0V, the default value is 600.0.
Float charge voltage	Can be set between 600.0~1500.0V, the default value is 600.0.
Topping Charge turn to Float Charge Current	Can be set between 0.0~3200.0A, the default value is 0.0.
End-of-charge current	Can be set between 0.0~3200.0A, the default value is 0.0.
Pre-charge voltage	Can be set between 600.0~1500.0V, and the default value is 600.0.
Maximum Pre-charge current	Can be set between 0.0~3200.0A, and the default value is 5.0.

Table 11-2 AC protection parameters

Active control mode	Specified P/ Volt-Watt / Freq-Watt / V-Watt & F-Watt
Reactive power control mode	Disable/ Fixed-Var/ Fixed-PF / Volt-Var / Watt-PF / Watt-Var certification-default.
Power Factor	Can be set between -1.00~1.00, default is 1.00. + Lagging - Leading
Active power (kW)	Can be set between -3200.0kW~3200.0kW, negative value means battery discharging, positive value means battery charging, the default value is 0.0.
Reactive power(KVar)	Can be set between -3200.0KVar~3200.0KVar, positive value means inductive reactive power, negative value means capacitive reactive power, default value is 0.0.
Power change rate	Can be set from 0.0001 to 3, certification-default.
Power change mode	The power change mode can be selected between "Step" and "Ramp".
Off-grid volt startup mode	Selectable between "Step" and "Soft Start".
Soft start ramp rate	Can be set from 0.0001 to 3, certification-default.

Off-grid voltage range	It can be set between 0.800 and 1.200 for off-grid voltage value adjustment, indicating ($x \times \text{rated voltage}$) V, x is the set value, and the default value is 1.000.
Simultaneous target voltage	Can be set between -0.1000~0.1000 for quasi-simultaneous voltage adjustment, indicating ($\text{rated voltage} + x \times \text{rated voltage}$) V, x is the set value, and the default value is 0.0000.
Simultaneous target frequency	Can be set between -0.1000~0.1000 for quasi-simultaneous frequency adjustment, indicating ($\text{target frequency} + x \times \text{target frequency}$) Hz, x is the set value, and the default value is 0.0000.
Grid-connected switch closure delay time	Can be set between 0~10000ms, the default value is 0.
Grid connection switch break delay time	Can be set from 0 to 10000ms, the default value is 0.
Ground fault enable	Can be selected between "Enable" and "Disable".
Islanding detection enable	Selectable between "Enable" and "Disable".
FVRT function	Selectable between "Enable" and "Disable".
Overvoltage section I protection ratio	Can be set from 1.000 to 1.350, certification-default
Overvoltage II protection ratio	Can be set between 1.000~1.350, certification-default.
Undervoltage I protection ratio	Can be set between 0.050~1.000, certification-default.
Undervoltage II protection ratio	Can be set from 0.050 to 1.000, certification-default.
Undervoltage III protection ratio	can be set from 0.050 to 1.000, certification-default.
Over-voltage I protection time	Can be set between 0~180.00s, certification-default.
Overvoltage II protection time	Can be set between 0~180.00s, certification-default.
Undervoltage I protection time	Can be set from 0 to 180.00s, certification-default.
Undervoltage II protection time	Can be set from 0 to 180.00s, certification-default.
Undervoltage III protection time	Can be set from 0 to 180.00s, certification-default.
Over frequency I protection ratio	Can be set between 0.01~6.00Hz, certification-default.
Over frequency II protection ratio	Can be set between 0.01~6.00Hz, certification-default.
Underfrequency I protection ratio	Can be set between -10~-0.01Hz, certification-default.
Underfrequency II protection ratio	Can be set between -10~-0.01Hz, certification-default.
Over frequency I protection time	Can be set between 0.00~650.00s, certification-default.
Over frequency II protection time	Can be set between 0.00~650.00s, certification-default.
Underfrequency I protection time	Can be set between 0.00~650.00s, certification-default.
Underfrequency II protection time	It can be set between 0.00~650.00s, certification-default.
Grid reconnection upper limit frequency	It can be set between 0.00~6.00Hz, certification-default.
Grid reconnection lower limit frequency	It can be set from -10.00 to -0.00Hz, certification-default.
Grid reconnection delay	Can be set between 0~1800s, certification-default.
Volt-VAr V1	can be set between 0.500 and 1.350, certification-default.
Volt-VAr V2	can be set between 0.500 and 1.350, certification-default.
Volt-VAr regulation Vref	can be set between 0.900 and 1.100, certification-default.
Volt-VAr V3	can be set between 0.500 and 1.350, certification-default.

Volt-VAr V4	can be set between 0.500 and 1.350, certification-default.
Maximum capacitive reactive Q1	can be set between -1.00 and 0.00 , certification-default. + Lagging - Leading
Initial capacitive reactive Q2	can be set between -1.00 and 1.00 , certification-default. + Lagging - Leading
Initial inductive reactive Q3	can be set between -1.00 and 1.00 , certification-default. + Lagging - Leading
Maximum inductive reactive Q4	can be set between -0.00 and 1.00 , certification-default. + Lagging - Leading
Volt/Var response time	Can be set from 0.00 to 90.00s, certification-default.
Volt/Vatt regulation start Volt point (High Volt)	can be set between 1.000 and 1.200, certification-default.
Volt/Vatt regulation end Volt point (High Volt)	can be set from 1.000 to 1.200, certification-default.
Volt/Vatt regulation start Power point (High Volt)	can be set between 0.00 and 1.00, certification-default.
Volt/Vatt regulation end Power point (High Volt)	can be set between -1.00 and 1.00, certification-default.
Volt/Vatt regulation recovery delay	Can be set from 0.00 to 90.00s, certification-default.
Volt/Vatt response time (High Volt)	Can be set from 0.00 to 90.00s, certification-default.
Freq/Watt regulation start Freq point(High Freq)	Can be set between 0.001~5.000Hz, certification-default.
Freq/Watt regulation ramp rate (High Freq)	Can be set between 0.0001~2.0000, certification-default.
Freq/Watt response time (High Freq)	Can be set between 0.00~90.00s, certification-default.

12 Contact

If you have technical questions about our products, please call our service hotline. Please provide the following information in order to give you helpful assistance

- Model number of the equipment
- Serial number of the device
- Specification of the battery
- Information about the PV module
- Current alarm information of the device
- Current AC and DC information of the device
- Software version of the device

SHENZHEN SINEXCEL ELECTRIC CO., LTD.

Website: www.sinexcel.us

Address: Bldg. 6, Baiwangxin Hi-tech Park, 1002 Songbai Rd., Shenzhen China 518000.

Postcode: 518055

Hotline: + 86 0755-8651-1588

